

Physical Security Solutions

Product Guide

ISSUE 2 | 2023

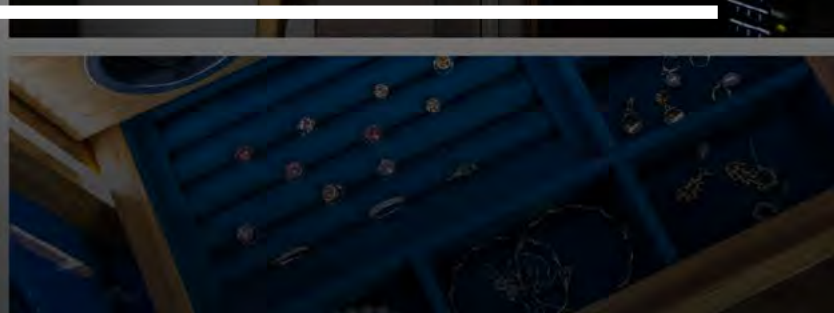

IF IT MATTERS TO YOU, SECURE IT WITH US..

BURTON SAFES	4	Heavy Duty Key Cabinets	78
Our comprehensive range	5	KG Keyguard Key Safes	78
Warranty & Lock Standards	6	IKMS Intelligent Key Cabinets	79
Safe Standards	7	Remote Key Safe	80
Test and Trade Organisations	8	Garage & Door Security	83
Awards	9	Garage Guard	84
Product Overview	11	Hasp Guard	84
		Shutter Guard	85
		Force Guard	85
		Disc Padlock	85
Home Safes	13	BURTONSAFES.DESIGN	86 - 89
Companion Fingerprint Safe	14	Ares	90 - 93
Jewellery Accessories	16	Brixia	94 - 99
Primo Home	18	Lusso	100 - 103
Torino Eurokey	18	Amario Lux	104 - 109
Torino S2	19	Krystal Display Safes	110 - 115
Eurovault Aver S2	20		
Burton Home Safe Grade S2	22	The Luxury Range	117
Burton Home Safe Grade G0	24	Eurovault LX The Luxury Range	118 - 119
Burton Home Safe Grade G1	26	THE SURE DEFENCE	120
Amario Grade 3	28	Embassy Modular Security Rooms	121- 133
		Orthrus Strongrooms	134
High Security Safes	30	Cerberus Vaults and Doors	136
Eurovault Aver Grades 0 - 5	32 - 37	Transporta Strongrooms	138
Eurovault Atlas Grades 6 - 7	38 - 39	Panzer Bunkers	139
		Armoured Security Doors	141
Safe Optional Extras	40	Janus Security Doors	142 - 145
		Metal+ Doors	146
Wall & Underfloor Safes	43	Kronos Security Doors	148
DK Wall	44	Panzer Blast Proof Doors BT	151
Unica Wall	44		
Burton Sotto	45	Related Security Products	152
Oculto	45	Ajax Grilles & Cages	153
		Typhon Bar Sets	153
Fire Safes	47	Talos Walling	154
Firesec 4/60	48	Avertic Armour	155
Firesec 10/60	49		
Firebrand	49	Safe Deposit	157
Firebrand XL	50	Shanghai Safe Deposit Boxes	158
Fire Resistant Filing Cabinets	50	Vienna Safe Deposit Boxes	160
		Vaduz Safe Deposit Box System	162
		Zurich Safe Deposit System	164
Gun Safes & Cabinets	53	ATM SAFE	166
Pioneer Gun Cabinet	54	ATM Room Protection	168
Warden LFS Gun Safe	55	Gas Attack Protection	168
Gamekeeper Gold	56	Safe Door Protection	169
		Pull Out & Cutting Protection	169
Hotel & Guest Safes	59	Ram Raid Protection	170
Hotel Standard	60	Door Pull Protection	170
Hotel Primo	60	Pull Out & Cutting Protection	171
Hotel Drawer	61	Dispenser & Cash Trapping Protection	171
Hotel Pop Up	61	OTC Smart CIT Lock	172
		Case Study	173
Retail Safes	63	ATM Delivery and Installation Services	175
Till Safe	64		
Teller Deposit	64	SAFE & VAULT	176
Cashguard	65	Reactive Safe Engineer and Locksmith Service	176
Eurovault Aver Deposit Grade 1	65	Delivery and Installation Services	177
High Security Deposit Safe Grade 2	66	Bespoke Security Solutions	177
High Security Deposit Safe Grade 3	66	The Sure Defence Standards	178
Safe Locks	68		
Burton Duo Fingerprint Lock	70		
Kaba Axessor USB Insys flex ID	72		
Safe Lock Terminology	73		
KEYGUARD	75		
Key Safes and Key Management	75		
Keyguard Digital XL	76		



Burton Safes are the trusted safe and vault supplier. With a high-quality product range of over 100 tested and certified fire and security safes we have been serving the Locksmith and business world for over 30 years.



We have a range of solutions for securing keys for the home, healthcare, garages, banks, hospitals, and business users which includes a range of Police preferred solutions, larger key storage solutions, remote critical access, and intelligent key management systems.



THE SURE DEFENCE

The Sure Defence Team provide a fully managed and personal high security service to protect your home or business. From initial sales advice, to survey, CAD drawings, supply, and installation we are one of the few UK companies providing the full design and engineering services in house.



Our award-winning ATM and Banking physical security systems and services are used by ATM manufacturers, financial institutions, independent ATM deployers and banks across the world. We offer protection systems for all known physical ATM attacks.



With our Design & Innovation engineering centre we are able to manufacture our own customised physical security products. We employ highly skilled, fully trained, and vetted safe & vault engineers to provide our customers with safe opening, repairs and installation services.

Safes and Secure Storage

Our comprehensive range of Home Safes and Domestic Security Solutions.

Burton Safes is extremely proud of how far we have come as a business. Our founder Norman Berry started selling a few safes from his garage in Kirkburton in 1990 to churches and the Locksmith trade.

30 years later we are now the UK's leading safe and vault provider and security company providing a large selection of physical security solutions to the trade, commercial and banking customers across the UK and around the world.

Burton Safes core principle is to ensure products are tested to the highest standards. We are proud to have tested products to LPCB standards and feature in RedBookLive.

Our SURE DEFENCE team are qualified in security design and consultancy. Dedicated account and project managers ensure an unrivalled customer experience.

We have created world-class and award-winning security products and services that keep you safe now and into the future.

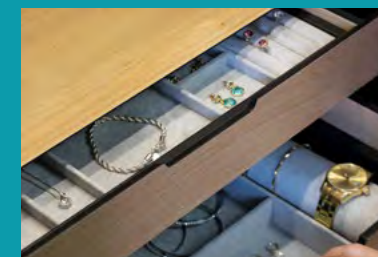

WARRANTY Up to 5 Years

All our safes come with a 2 year warranty as standard. Consumers can Register on-line to increase the warranty to 5 years where products show the 5 Year Consumer Warranty badge.
Security Safes displaying the Home series Safe For Longer free replacement badge benefit from the 5 year warranty and a free replacement in the event of burglary.
Fire and security safes displaying the Home Series Safe For Longer badge benefit from the 5 year warranty and a free replacement in the event of burglary or a fire.



5 Year consumer warranty badge



Free replacement in the event of burglary badge



Free replacement in the event of burglary or fire badge

Please register online to qualify for the additional warranty at www.burtonsafes.co.uk
Terms and conditions apply

SAFE LOCK Standards

EN1300 - This is a standard for safe locks. The locks are subjected to various durability and manipulation tests and given one of four grades from A - D.

All safes and strongrooms certified to EN14450 and EN1143-1/2 must have a certified lock that reflects the grade of the safe

- **EN14450** and EN1143-1/2 Grade 0-II must have 1 lock certified to Class A
- **EN1143-1/2** Grade III must have 1 lock certified to Class B
- **EN1143-1/2** Grade IV and V must have 2 locks certified to Class B
- **EN1143-1/2** Grade VI to X must have 2 locks certified to Class C



SAFE Standards

Every safe and vault which is certified to EN 14450, EN 1143-1 & EN 1143-2 should have a certification plate on the back of the door. This gives you important information about the product and its security rating.

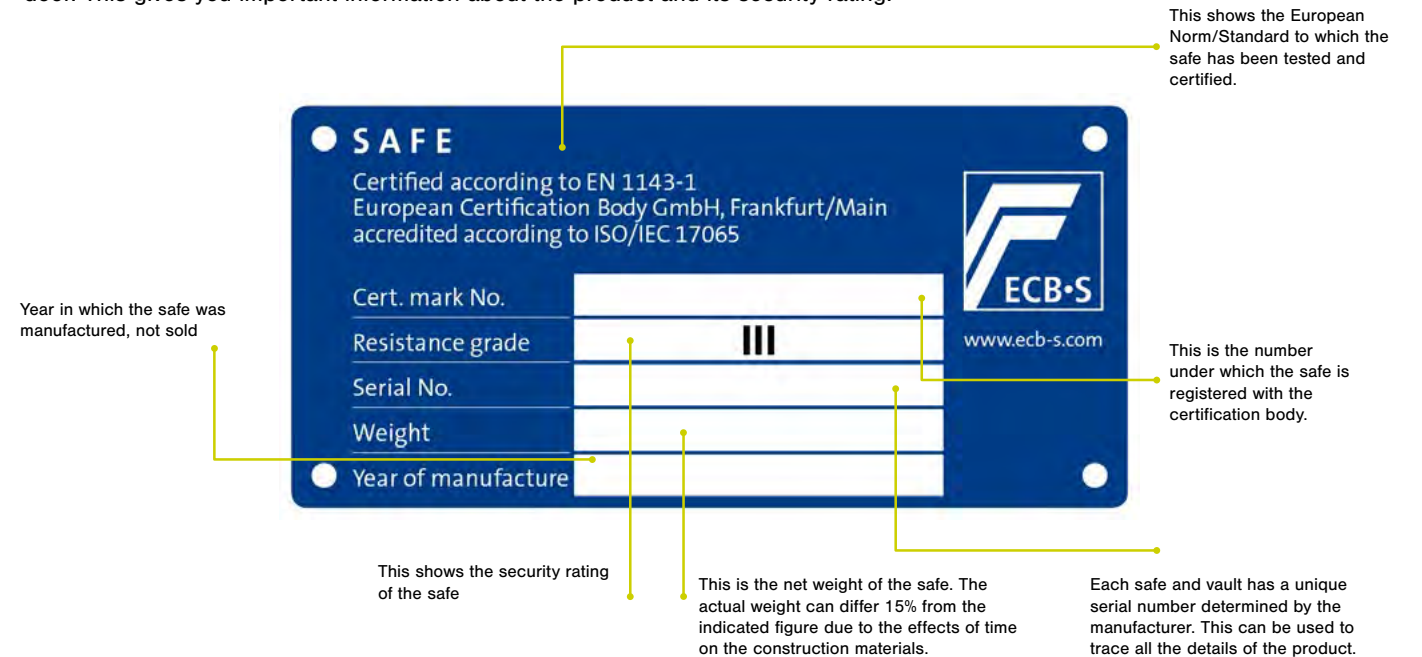

EN14450 - This is a burglary attack test standard for safe cabinets. It largely covers smaller, home safes and cabinets for commercial applications. Safes are attacked using a set list of tools, and scores are given depending on the time taken to make hand holes and larger full size access holes

EN1143-1 - This is a burglary attack test standard for Safes, ATMs and strong rooms. It is the main standard used throughout Europe to assess the security level of safes and it is much more demanding than EN14450. Safes are attacked using a set list of tools, and scores are given depending on the time taken to make hand holes and larger full size access holes. There is a large range of security grades within the standard from 0-XIII. There are also optional tests to prove resistance against core drilling CD and explosives EX

EN1143-2 - This is a very similar standard to EN1143-1 but it is specifically designed for deposit safes and systems. In addition to the normal tests of EN1143-1 there are additional tests to assess the ability to fish items out of the deposit systems. If you are purchasing a certified deposit safe, make sure that it is certified to EN1143-2 and not EN1143-1

Safe Fire Standards

EN1047 - This is a very rigorous fire test for safes and data rooms. Safes are subjected to very high external temperatures inside a furnace of approximately 900 °C. Internal temperatures are closely monitored with numerous thermo-couples. There are three levels of protection given:

- P** - Paper documents that will lose data above 170 °C
- D** - Computer media that will lose data above 70 °C and humidity above 85%
- DIS** - Computer media that will lose data above 50 °C and 85% humidity

This particularly tough standard also includes a drop test to simulate a safe falling through a collapsed floor, and a soak out period, where the safe must naturally cool down as it would in a real life situation

EN15659 - This is a similar standard to EN1047 but it does not include the drop test or the soak out period. It is therefore not quite as rigorous. It also only covers protection for paper, not computer data

Gun Cabinet Standards

Sold Secure - A burglary attack test covering various products including home safes, cabinets, key safes, gun safes and gun cabinets. They have three ratings of Gold, Silver and Bronze

BS7558 - This is a British standard for gun cabinets. The required threshold to pass this test is lower than EN14450 or EN1143-1

TEST AND TRADE Organisations

Test and Certification Bodies

ECB•S

A world renowned German certification body, certifying safes, strongrooms, ATMs and security doors. They are accredited to ISO-IEC 17065.



ICIM

This is an Italian certification body.



LPCB

This is the Physical Security test and certification arm of BRE. BRE is a much larger, British testing and certification body with a global reputation.



SBSC

This is a Swedish certification body.



Secured by Design

This is a UK Police run initiative offering certification to multiple security products and also wider schemes.



Sold Secure

This is a British test and certification body, owned and run by the Master Locksmiths Association.



VDS

Leading German testing and certification facility.



Trade Organisations

AiS

The Association of Insurance Surveyors is a UK body of risk control and reduction experts, who work within the insurance market.



ESSA

This is a global trade organisation for Safe, Strongroom, ATM and Security Door manufacturers and distributors.



BRITISH SAFE AND VAULT TRADE ASSOCIATION - BSVTA

is the UK trade body for the safe industry. They promote good standards, certification and ethical practices.



Eurosafe

This is the European parent organisation of BSVTA.



MLA

Master Locksmiths Association is the main trade body in the UK for locksmiths.



Secured by Design

This is a Police accreditation scheme for security product manufacturers and distributors.



NAEP

Founded in 1997, organisation championing the appropriate care equipment in the community.



FSQS

Community of financial institutions including banks, building societies, insurance companies and investment services that form a buying group.



Safe Contractor

Being part of the Safecontractor accreditation scheme checks mean we meet the necessary requirements around health and safety, equal opportunities, diversity and environmental management practices. So our clients can be confident about us and reduce risk in their supply chain.



ATMIA

ATMIA is the leading non-profit trade association representing the entire global ATM industry. ATMIA serves more than 11,000 members from over 650 companies located in 70 countries spanning the entire ATM ecosphere, including financial institutions, independent ATM deployers, equipment manufacturers, processors and a plethora of ATM service and value-added solution providers.



E.A.S.T

The European Association for Secure Transactions was formed as the European ATM Security Team in 2004 to focus on ATM security when card skimming was a rising issue in Europe. Its remit now covers both Terminal Security and Payment Security.



Awards

IFSEC

Burton Safes are delighted to have won the IFSEC Physical Security Product of the Year 2013 award. The award was given for the Eurovault Atlas Grade 7, the UK's highest rated security safe to have passed the European EN1143-1 Grade 7 attack test.



IFSEC / FIREX

IFSEC AND FIREX COMBINED SECURITY & FIRE SOLUTION OF THE YEAR WINNERS What a result for the GP-X, designed and manufactured by the ATM SAFE team! We won Combined Security and Fire Solution of the Year at the IFSEC Security Excellence Awards 2015.



ATMIA

WINNER of the prestigious 2018 ATMIA Global Industry Security Award for ATM Physical Security Excellence for our best-in-class ATM gas attack and fire protection system the GP-X.





*We protect what
you care most about!*

PRODUCT OVERVIEW

Product	Rating	Certification
HOME SAFES		
Companion Fingerprint Safe	n/a	Recommended £3,000 Cash Rating
Primo Home	n/a	n/a
Torino Eurokey	n/a	Recommended £3,000 Cash Rating
Torino S2	EN14450	S2
Eurovault Aver S2	EN14450	S2
Burton Home Safe Grade S2	EN14450	S2
Burton Home Safe Grade 0	EN1143-1 & EN15659	Grade 0 & LFS 30P
Burton Home Safe Grade 1	EN1143-1	Grade 1
Amario Grade 3	EN1143-1	Grade 3
HIGH SECURITY SAFES		
Eurovault Aver Grade 1	EN1143-1 & EN15659	Grade 1 & LFS 30P
Eurovault Aver Grade 2	EN1143-1 & EN15659	Grade 2 & LFS 30P
Eurovault Aver Grade 3	EN1143-1 & EN15659	Grade 3 & LFS 30P
Eurovault Aver Grade 4	EN1143-1 & EN15659	Grade 4 & LFS 30P
Eurovault Aver Grade 5	EN1143-1 & EN15659	Grade 5 & LFS 30P
Eurovault Atlas Grade 6	EN1143-1	Grade 6
Eurovault Atlas Grade 7	EN1143-1	Grade 7
WALL & FLOOR SAFES		
DK Wall Safe	EN14450	S2
Unica Wall Safe	EN14450	Grade 0
Sotto	EN14450	S2
Oculto	n/a	Recommended £17,500 Cash Rating
FIRE SAFES		
Firesec 4/60	EN1143-1 & EN15659	S2 & LFS 60P
Firesec 10/60	EN1143-1 & EN15659	Grade 1 & LFS 60P
Firebrand	EN15659	LFS 60P
Firebrand XL	EN15659	LFS 60P
Fire Resistant Filing Cabinets	EN15659	LFS 60P
GUN SAFES & CABINETS		
Pioneer Gun Cabinet	SS302:2020	Bronze
Warden LFS Gun Safe	SS302:2020	Silver
Gamekeeper Gold	SS302:2020	Gold
HOTEL SAFES		
Hotel Standard	n/a	n/a
Hotel Primo	n/a	n/a
Hotel Drawer	n/a	n/a
Hotel Pop Up	n/a	n/a
KEY SAFES & CABINETS		
Keyguard Digital XL	LPS1175	Issue 8 A5
KG Keyguard Key Safes	n/a	n/a
Heavy Duty Key Cabinets	n/a	n/a
IKMS Intelligent Key Cabinets	n/a	n/a
Remote Key Safe	n/a	n/a
GARAGE SECURITY		
Garage Guard	Domestic Security	Silver
Hasp Guard	n/a	n/a
Shutter Guard	n/a	n/a
Force Guard	n/a	n/a
RETAIL SAFES		
Till Safe S2	EN14550 & EN1143-1	S2
Till Safe Grade 1	EN1143-1 & EN15659	Grade 1 & LFS 30P
Teller Deposit	n/a	Recommended £1,000 - £3,000 Cash Rating
Cashguard Vehicle	n/a	n/a
Eurovault Aver Deposit Grade 1	EN1143-2	Grade 1
High Security Deposit Grade 2	EN1143-2	Grade 2
High Security Deposit Grade 3	EN1143-2	Grade 3
LUXURY & DESIGN SAFES		
Ares S2	EN1143-1	S2
Lusso	EN1143-1 & EN15659	Grade 2 to Grade 3 & LFS30P
Brixia	EN1143-1	Grade 1 & Grade 3
Amario Lux	EN1143-1	Grade 3 & Grade 4
Eurovault LX	EN1143-1 & EN15659	Grade 1 to Grade 5 & LFS30P
Eurovault LX	EN1143-1	Grade 6 & Grade 7



Home and offices safes

Home Safes

Our Home Series are the perfect security furnishing for any residence. With products ranging from £10k jewellery rating to £350k jewellery rating there is something for every need. All safes from £40k valuables rating are certified by internationally recognised test houses and are validated in the UK by the **Association of Insurance Surveyors**, providing peace of mind when storing those treasured possessions.

*Safe for Longer - The Burton home series provides consumers with a 5 year warranty and a FREE REPLACEMENT if the safe is damaged in the event of a burglary.**

*See the warranty section of our website for full terms and conditions. For those prized possessions Burton Safes are The Sure Defence®





COMPANION Fingerprint Safe



Cash Rating
£3,000



Jewellery Rating
£30,000



- Backlit keypad and interior carpet
- Anti-bump, motorised locking bolts
- 3-6 digit code
- Emergency override key
- Battery level indicator with low consumption motor
- Back and base fixing
- Smart talking safe

Locking Options



Pin



Biometric

Model	External (HxWxD)	Internal (HxWxD)	Weight	Volume	Shelves
Size 1	500 x 450 x 450	465 x 440 x 365	45kg	74L	1



THE IDEAL COMPANION SAFE

Want something a little special, then look at our new Companion fingerprint safe. The perfect bedside table, armchair or office safe for keeping those keys, passports, cash, and other valuables safe in one place over night. A safe that is not just a safe, but part of your everyday life at a touch of the finger...

- Access the safe using a fingerprint or PIN code
- Up to 50 fingerprints and PIN codes can be programmed
- User programmable 6 digit PIN code
- Anti-bump motorised locking bolts
- Faux leather lined door in grey
- Faux-leather lined with diamond stitching
- Smart talking safe
- Comes with a fixed height shelf
- Low battery warning
- Emergency opening using a USB-C cable
- Features an internal LED, key hooks and a document holder
- Back and base fixing

SECURITY AND PRIVACY AT A TOUCH OF FINGER



Your smart talking safe

JEWELLERY ACCESSORIES

Stackers™ and Watch Winders

The essential way to store and secure your most precious possessions.



Stacker 3



Watch winder

Ensure your valuables are maintained in the best condition by keeping your jewellery in the velvet lined compartments.

We have a range of sizes and layouts to accommodate all jewellery and trinkets.

Call the office for information on which models can fit into each safe. **+44 (0) 1484 663388**

Model	Layout	Sizes
Watch winder cub	1 watch	145 x 135 x 115
Stacker 1	Mini Open Stacker	70 x 180 x 125
Stacker 2	White Medium Jewellery Slider	35 x 305-475* x 260
Stacker 3	Mink Classic 3 Section Tray - Mini	60 x 250 x 180
Stacker 4	Mink Classic Necklace Layer	35 x 250 x 180
Stacker 5	Mink Classic 4 Section Jewellery Tray	35 x 250 x 180
Stacker 6	Black Classic Watch Box with clear lid - 8 watches	100 x 240x 190

* Stacker 2 can be extended. 305mm is the width when closed, 475mm is the width when the lower trays are opened.



Stacker 6



Stacker 2





Primo Home Safe

 **Cash Rating**
£1,000

 **Jewellery Rating**
£10,000

- Backlit keypad and interior carpet
- Anti-bump, motorised locking
- 3-6 digit code
- Emergency override key
- Battery level indicator with low consumption motor
- Back and base fixing

Locking Options

 Pin

Size 2

Model	External (HxWxD)	Internal (HxWxD)	Weight	Volume	Shelves
Size 1	200 x 300 x 200	195 x 295 x 150	7kg	8L	-
Size 2	250 x 350 x 250	225 x 345 x 200	11kg	15L	1

Add 20mm to external depth for keypad



Torino Eurokey

 **Cash Rating**
£3,000

 **Jewellery Rating**
£30,000

- Locking via patented euro-profile cylinder
- Keys are easier to carry than traditional safe keys
- Have one key to operate your safe, your front door and your office
- Add your own euro-cylinder if preferred
- Removable shelf
- Back and base fixing

Locking Options

 Single Key

Model	External (HxWxD)	Internal (HxWxD)	Weight	Volume	Shelves
Size 1	280 x 400 x 350	260 x 390 x 295	37kg	30L	1
Size 2	350 x 470 x 350	330 x 460 x 295	44kg	45L	1



Size 4



Torino S2

 **Cash Rating**
£4,000

 **Jewellery Rating**
£40,000

- Independently attack tested and certified to EN14450 S2 by ICIM*
- Insurance approved by the AiS
- The best build quality and security level in its class
- Smart metallic black paint finish
- Flush fitting door and keypad make this safe ideal for use in bedroom cupboards
- Electronic locking options including flush keypad, emergency override key and external battery power point in case of lock out
- Removable shelf
- Back and base fixing

Locking Options

 Single Key  Pin



Model	External (HxWxD)	Internal (HxWxD)	Weight	Volume	Shelves
Size 1	220 x 350 x 300	200 x 340 x 245	26kg	16L	1
Size 2	280 x 400 x 350	260 x 390 x 295	37kg	30L	1
Size 3	350 x 470 x 350	330 x 460 x 295	44kg	45L	1
Size 4	490 x 430 x 400	470 x 420 x 345	62kg	68L	1

*Size 1 not certified





Size 3

Eurovault Aver S2

 **Cash Rating**
£4,000

 **Jewellery Rating**
£40,000



- Independently tested and certified to EN14450 S2 by ECB•S
- Insurance approved by the AiS
- Built to a Police Preferred Specification - Secured by Design
- Ideal home, office, or change safe
- Option of key or electronic locking in all sizes
- Electronic lock features 1 master code and 9 user codes with dual user and time delay functions
- Removable shelf in sizes 1-3, height adjustable shelving in sizes 4-6
- Single back and base fixing
- We also have an S2 Till safe featured on page 64



Locking Options



Single Key



Pin



Model	External (HxWxD)	Internal (HxWxD)	Weight	Volume	Shelves
Size 1	300 x 350 x 300	220 x 270 x 195	19kg	11L	1
Size 2	300 x 445 x 400	220 x 365 x 295	24kg	23L	1
Size 3	450 x 445 x 400	370 x 365 x 295	31kg	39L	1
Size 4	600 x 445 x 400	520 x 365 x 295	38kg	56L	2
Size 5	800 x 445 x 400	720 x 365 x 295	48kg	77L	2
Size 6	1000 x 445 x 400	920 x 365 x 295	58kg	99L	2

Add 12mm to external depth for keypad



Size 4



Size 5



Size 6



Burton Home Safe S2

 **Cash Rating**
£4,000

 **Jewellery Rating**
£40,000

- Easy to use digital safe lock
- Insurance approved by the AiS
- SBD Police Approved Specification
- Independently attack tested to domestic safe and certified for insurance purposes to EN14450 Grade S2 by Sold Secure
- Includes 1 removable shelf
- Back and base fixing
- Installs to floors and walls (fixing kit included)



Locking Options

 Electronic

Model	External (HxWxD)	Internal (HxWxD)	Weight	Volume	Shelves
Size 1	300 x 350 x 300	220 x 270 x 190	17kg	11L	1
Size 2	300 x 445 x 400	220 x 365 x 290	28kg	23L	1
Size 3	450 x 445 x 400	365 x 365 x 290	31kg	39L	1

Add 12mm to external depth for keypad

The ideal home & office safe

Size 1



Size 3



Size 2

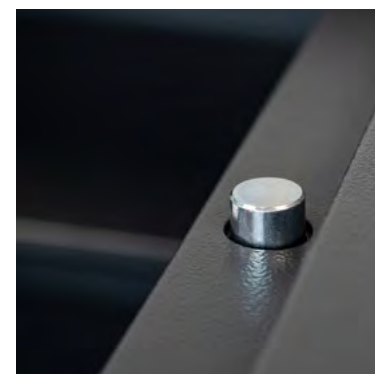

Burton Home Safe S2

Burton Home Safe Grade 0



Cash Rating
£6,000



Jewellery Rating
£60,000



Fire Rating 30 minute
Fire protection for paper



- Independently attack tested and certified to EN1143-1 Grade 0 and EN15659 LFS 30P
- Insurance approved by the AiS
- Built to a Police Preferred Specification - Secured by Design
- 30 minutes fire protection for paper
- High security electronic PIN code lock
- Electronic lock features 1 master code and 9 user codes with dual user and time delay functions
- Fixed shelving in size 1 & 2, height adjustable shelving in size 3 & 4
- Back and base fixing



Locking Options

OOOO Pin

Model	External (HxWxD)	Internal (HxWxD)	Weight	Volume	Shelves
Size 1	300 x 400 x 300	215 x 320 x 165	65kg	11L	1
Size 2	300 x 450 x 400	215 x 370 x 265	87kg	21L	1
Size 3	450 x 450 x 400	365 x 370 x 260	118kg	34L	1
Size 4	655x 440 x 430	580 x 360 x 335	158kg	62L	1

Add 28mm to external depth for keypad and hinges

Securely store your valuables at home!



Burton Home Safe G0

New Size 4





Burton Home Safe Grade 1

 **Cash Rating**
£10,000

 **Jewellery Rating**
£100,000



- Available in 3 compact sizes
- High security digital safe lock
- SBD Police Approved Specification
- Independently attack tested and certified for insurance purposes to EN1143-1 Grade 1 by ECB•S
- AiS Insurance Approved
- Includes 1 height adjustable shelf
- Back and base fixing
- Installs to floors and walls (fixing kit included)



Locking Options

 Pin

Model	External (HxWxD)	Internal (HxWxD)	Weight	Volume	Shelves
Size 1	400 x 400 x 270	350 x 350 x 155	39kg	18L	1
Size 2	400 x 420 x 420	350 x 370 x 305	55kg	39L	1
Size 3	500 x 500 x 420	450 x 450 x 305	71kg	61L	1

Add 28mm to external depth for keypad and hinges



New Burton Home Safe Grade 1



**AVAILABLE
IN 3 COMPACT SIZES**



Amario Size 2



Amario Grade 3

 **Cash Rating**
£35,000

 **Jewellery Rating**
£350,000



- Independently tested and certified to EN1143-1 Grade 3 by ECB•S
- Insurance approved by the AiS
- Built to a Police Preferred Specification
 - Secured by Design
- Small and sleek design to fit into domestic wardrobes and cupboards
- Options of high security key or electronic lock
- Lock features LED light for use in dark rooms
- Option of left hand hinge - additional lead times and costs apply
- Dual locking available on Size 2
- Back and base fixing

Locking Options



Model	External (HxWxD)	Internal (HxWxD)	Weight	Volume	Shelves
Size 1	350 x 440 x 350	250 x 340 x 180	130kg	18L	1
Size 2	500 x 450 x 450	400 x 350 x 295	210kg	41L	2

Add 55mm to external depth for handle



*We protect what
you care most about!*

High Security Safes

From £100k jewellery rating to Europe's Highest security safe providing £2.5M jewellery rating; all of our high security products are independently tested and certified by internationally recognised test houses and validated by the Association of Insurance Surveyors.

At Burton Safes we work on some of the world's most secure sites. That experience filters into our products and the benefits reach you. Our range contains models with features such as double walled steel products with ultra-high performance concrete, certified fire protection, relocking devices, glass plates, and special drill protective elements for the lock and bolt work.

We deliver key and electronic locking solutions, including the use of the latest biometric technology.

Our locking solutions include features such as alarm and CCTV integration, dual user entry, time delays and windows, duress codes, temporary and one user time codes to name a few. We also have a wide range of optional extras to provide for every eventuality, whether that be jewellery inserts or additional shelves.

HIGH SECURITY SAFES



EUROVAULT AVER & ATLAS Grades 1 to 7

Wide selection of sizes available
Insurance approved by the AiS
Built to a Police Preferred Specification
Secured by Design

Security level	Cash Rating	Jewellery Rating	Fire Protection
Grade 1	£10,000	£100,000	30 Minutes
Grade 2	£17,500	£175,000	30 Minutes
Grade 3	£35,000	£350,000	30 Minutes
Grade 4	£60,000	£600,000	30 Minutes
Grade 5	£100,000	£1,000,000	30 Minutes
Grade 6	£150,000	£1,500,000	N/A
Grade 7	£250,000	£2,500,000	N/A



G1-G5



G6-G7

Locking Options



Single Key



Dual Locking



Pin



Biometric



Dial

Discuss your requirements with us!



Size 3

Size 4

Size 5

Size 1

Size 2



Eurovault Aver Grade 1



Cash Rating
£10,000



Jewellery Rating
£100,000



Fire Rating 30 minute
Fire protection for paper



- Independently tested and certified to EN1143-1 Grade 1 and EN15659 LFS30P by ECB+S
- Insurance approved by the AiS
- Built to a Police Preferred Specification - Secured by Design
- Suitable for storage of controlled drugs with active ingredients exceeding 500g
- Option of left hand hinge - additional lead times and costs apply
- Height adjustable shelving
- Back and base fixing
- We also have a Grade 1 Deposit Safe featured on page 65

Locking Options



Single Key



Pin



Model	External (HxWxD)	Internal (HxWxD)	Weight	Volume	Shelves
Size 1	340 x 500 x 345	262 x 424 x 216	93kg	24L	1
Size 2	460 x 440 x 430	382 x 364 x 300	119kg	42L	1
Size 3	655 x 440 x 430	574 x 364 x 300	155kg	63L	1
Size 4	900 x 440 x 430	822 x 364 x 300	205kg	90L	2
Size 5	840 x 650 x 550	782 x 574 x 420	289kg	189L	2

Add 55mm to external depth for handle



Eurovault Aver Grade 2

 **Cash Rating**
£17,500

 **Jewellery Rating**
£175,000

 **Fire Rating 30 minute**
Fire protection for paper



- Independently tested and certified to EN1143-1 Grade 2 and EN15659 LFS 30P by ECB•S
- Insurance approved by the AiS
- Built to a Police Preferred Specification - Secured by Design
- Suitable for storage of controlled drugs with active ingredients exceeding 500g
- Choose from high security key or electronic locking
- Option of dual locking - not sizes 0 & 1
- Option of left hand hinge - additional lead time and costs apply
- Cable hole for alarm connection
- Height adjustable shelving
- Back and base fixing
- We also have a Grade 2 Deposit Safe featured on page 66

Locking Options

Any lock alterations must conform to EN1300 Class A.



Single Key



Dual Locking

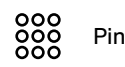

Pin



Biometric



Dial

Model	External (HxWxD)	Internal (HxWxD)	Weight	Volume	Shelves
Size 0	460 x 470 x 470	345 x 355 x 320	180kg	39L	1
Size 1	500 x 510 x 510	385 x 395 x 360	211kg	55L	1
Size 2	670 x 510 x 510	555 x 395 x 360	262kg	79L	1
Size 3	610 x 680 x 510	495 x 565 x 360	297kg	100L	1
Size 4	810 x 680 x 510	695 x 565 x 360	368kg	141L	2
Size 5	1010 x 680 x 510	895 x 565 x 360	439kg	182L	2
Size 6	1320 x 680 x 510	1205 x 565 x 360	552kg	244L	3
Size 7	1510 x 850 x 600	1375 x 715 x 440	863kg	431L	3

Add 55mm to external depth for handle



Eurovault Aver Grade 3

 **Cash Rating**
£35,000

 **Jewellery Rating**
£350,000

 **Fire Rating 30 minute**
Fire protection for paper



- Independently tested and certified to EN1143-1 Grade 3 and EN15659 LFS 30P by ECB•S
- Insurance approved by the AiS
- Built to a Police Preferred Specification - Secured by Design
- Suitable for storage of controlled drugs with active ingredients exceeding 500g
- Choose from high security key or electronic locking
- Option of dual locking - not sizes 0 & 1
- Option of left hand hinge - additional lead time and costs apply
- Cable hole for alarm connection
- Height adjustable shelving
- Back and base fixing
- We also have a Grade 3 Deposit Safe featured on page 62

Locking Options

Any lock alterations must conform to EN1300 Class B.



Single Key



Dual Locking



Pin



Biometric



Dial

Model	External (HxWxD)	Internal (HxWxD)	Weight	Volume	Shelves
Size 0	500 x 510 x 510	385 x 395 x 330	229kg	50L	1
Size 1	670 x 510 x 510	555 x 395 x 330	281kg	72L	1
Size 2	990 x 510 x 510	875 x 395 x 330	387kg	113L	2
Size 3	1320 x 680 x 510	1205 x 565 x 330	591kg	223L	2
Size 4	1320 x 850 x 510	1185 x 715 x 315	757kg	268L	3
Size 5	1660 x 680 x 510	1525 x 545 x 315	789kg	263L	3
Size 6	1660 x 850 x 510	1525 x 715 x 315	920kg	345L	3

Add 55mm to external depth for handle



Eurovault Aver Grade 4

-  **Cash Rating**
£60,000
-  **Jewellery Rating**
£600,000
-  **Fire Rating 30 minute**
Fire protection for paper



- Independently tested and certified to EN1143-1 Grade 4 and EN15659 LFS 30P by ECB•S
- Insurance approved by the AiS
- Built to a Police Preferred Specification - Secured by Design
- Dual locking as standard - combination of key and/or electronic as required
- Kaba Connect with lock mount fitted as standard on dual electronic models
- Burton Safes recommends Kaba Connect is used with mains power
- Alternative electronic locks available upon request
- Network or one time code lock options available
- Cable hole for alarm connection
- Option of left hand hinge - additional lead time and costs apply
- Height adjustable shelving
- Back and base fixing

Locking Options

Any lock alterations must conform to EN1300 Class B.





Model	External (HxWxD)	Internal (HxWxD)	Weight	Volume	Shelves
Size 1	550 x 550 x 530	435 x 435 x 335	297kg	64L	1
Size 2	670 x 550 x 530	555 x 435 x 335	348kg	81L	1
Size 3	840 x 550 x 530	725 x 435 x 335	420kg	106L	1
Size 4	1010 x 550 x 530	895 x 435 x 335	484kg	131L	2
Size 5	1510 x 680 x 560	1425 x 545 x 355	905kg	276L	3

* Add 55mm to external depth for handle. Kaba Connect lock with mount protrudes 90mm.



Eurovault Aver Grade 5

-  **Cash Rating**
£100,000
-  **Jewellery Rating**
£1,000,000
-  **Fire Rating 30 minute**
Fire protection for paper



- Independently tested and certified to EN1143-1 Grade 5 and EN15659 LFS 30P by ECB•S
- Insurance approved by the AiS
- Built to a Police Preferred Specification - Secured by Design
- Dual locking as standard - combination of key and/or electronic as required
- Kaba Connect with lock mount fitted as standard on dual electronic models
- Burton Safes recommends Kaba Connect is used with mains power
- Alternative electronic locks available upon request
- Network or one time code lock options available
- Cable hole for alarm connection
- Option of left hand hinge - additional lead time and costs apply
- Height adjustable shelving
- Back and base fixing

Locking Options

Any lock alterations must conform to EN1300 Class B.



Model	External (HxWxD)	Internal (HxWxD)	Weight	Volume	Shelves
Size 1	680 x 680 x 630	540 x 540 x 380	600kg	111L	1
Size 2	840 x 680 x 680	700 x 540 x 430	695kg	163L	1
Size 3	1010 x 680 x 680	870 x 540 x 430	808kg	203L	2
Size 4	1510 x 680 x 680	1370 x 540 x 430	1152kg	320L	3

* Add 55mm to external depth for handle. Kaba Connect lock with mount protrudes 90mm.





Eurovault Atlas Grade 6



Cash Rating
£150,000



Jewellery Rating
£1,500,000



- Independently tested and certified to EN1143-1 Grade 6 by SBSC
- Insurance approved by the AiS
- Built to a Police Preferred Specification - Secured by Design
- Dual locking as standard - combination of key and/or electronic as required
- Option of left hand hinge - additional lead time and costs apply
- Height adjustable shelving
- Base fixing

Locking Options

Any lock alterations must conform to EN1300 Class C.

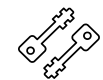

Dual Locking

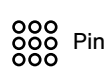

Pin



Biometric



Dial

Model	External (HxWxD)	Internal (HxWxD)	Weight	Volume	Shelves
Size 1	1080 x 690 x 660	900 x 500 x 400	1162kg	180L	2
Size 2	1380 x 690 x 660	1200 x 500 x 400	1390kg	240L	2
Size 3	1680 x 690 x 660	1500 x 500 x 400	1610kg	300L	4

Add 25mm to external width for hinges, Add 55mm to external depth for handle and electronic lock options



Eurovault Atlas Grade 7



Cash Rating
£250,000



Jewellery Rating
£2,500,000



- The highest security rated safe available in Europe
- Independently tested and certified to EN1143-1 Grade 7 by SBSC
- Insurance approved by the AiS
- Built to a Police Preferred Specification - Secured by Design
- Dual locking as standard - combination of key and/or electronic as required
- Option of left hand hinge - additional lead time and costs apply
- Height adjustable shelving
- Base fixing

Locking Options

Any lock alterations must conform to EN1300 Class C.

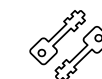

Dual Locking

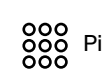

Pin



Biometric



Dial

Model	External (HxWxD)	Internal (HxWxD)	Weight	Volume	Shelves
Size 1	1150 x 760 x 730	900 x 500 x 400	1650kg	180L	2
Size 2	1450 x 760 x 730	1200 x 500 x 400	1950kg	240L	2
Size 3	1750 x 760 x 730	1500 x 500 x 400	2350kg	300L	4

Add 25mm to external width for hinges, Add 55mm to external depth for handle and electronic lock options

SAFE OPTIONAL Extras

Internal Light

- Enables you to see your belongings, even when your safe is in a dark cupboard
- Belongings can be displayed as well as protected
- Uses magnets to attach to the safe interior, no installation required
- Batteries included



Shelves

Additional, replacement and reinforced shelves holding up to 50kg. We have a wide range to suit our products and your needs.



Left Hand Hinge

Where available Burton Safes can provide your safe with a left-hand hinge.

Fixing

We have a range of fixing kits available to install your safe:

- Concrete
- Wood
- Chemical
- Adhesive
- Plinths
- Underfloor



Colour Options

Available on nearly all of our range - we can offer a choice of paint colours on most of our safe models. Choose from our 4 most popular colours or supply your own RAL colour for the exterior of the safe.

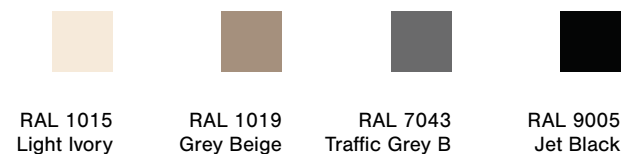

Safe Limpets

- Piezo vibration detector
- Integral analyser
- Thermal and proximity sensor
- Magnetic interference and supply failure detection
- Connects to your building alarm system
- Prevents operation of your safe whilst the alarm is activated



Signal Blocker

The sure defence for contactless cards, keyless vehicle keys and distracted driving.

- Police Preferred Specification
- Fits all key fobs, smart cards and phones
- Blocks all signals from cards, key fobs and phones
- Blocks GPS tracking
- Expertly tested to a 99% success rate
- Double stitched reinforced seams
- Spare pouch



We can also provide door contacts and opening counters

Safe Deposit Options

Add deposit features to your safe!

- Internal coffer
- Deposit slots
- Preparation for air tubes

Seismic Sensor

- Detects specific vibrations from unauthorised attempts to penetrate the safe
 - Fast reacting alarm system
- Has optimum sensitivity, detecting unauthorised access and preventing false alarms
 - Suitable for noisy environments





Wall & Underfloor Safes

Our range of Wall and Underfloor safes provide a concealed option to protecting cash, documents and valuables. From deterring thieves and satisfying insurance requirements, to providing protection from flood damage.

Installing a Wall or Underfloor safe can help where space is a premium or where security and peace of mind of a hidden safe is desired.

Our wall safes are ideal for operating at head level and keeping away from ground level should flooding be a risk. With a £4k cash, £40k valuables and £6k cash and £60k valuables options we should have you covered.

The Sotto underfloor safe is unique by providing an adjustable telescopic depth adjustment, stylish dust cover lid and recommended £4k cash and £40k valuables cover.

The Oculito underfloor safe is supplied with a high quality water-tight lid, steel mesh neck with a recommended £17.5k cash and £175k valuables cover.



Size 3

DK Wall Safe

 **Cash Rating**
£4,000

 **Jewellery Rating**
£40,000



- Independently tested and certified to EN14450 S2 by ICIM - not size 1 & 2
- Insurance approved by the AiS
- Easily concealed wall safe with flush facia
- Designed to be set in reinforced concrete
- Option of high security key or electronic locking
- The electronic lock includes an emergency over ride key and external battery power point in case of lock out

Locking Options

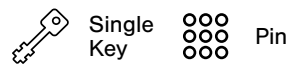

Model	External (HxWxD)	Internal (HxWxD)	Weight	Volume	Shelves
Size 1	210 x 270 x 150	185 x 245 x 100	10kg	5L	-
Size 2	210 x 340 x 150	185 x 315 x 100	13kg	6L	1
Size 3	270 x 390 x 200	245 x 365 x 150	20kg	13L	1
Size 4	340 x 460 x 200	315 x 435 x 150	26kg	21L	1

Burton Sotto

 **Cash Rating**
£4,000

 **Jewellery Rating**
£40,000



- Independently tested and certified to EN14450 S2 by ICIM
- Door opening assisted by gas spring
- Unique adjustable height from 210mm to 320mm to suit your needs
- Designed to be set into reinforced concrete in the floor of a building
- High security double bitted key lock
- Includes stylish dust cover lid

Locking Options



Model	External (HxWxD)	Internal (HxWxD)	Weight	Volume	Shelves
Sotto	210-320* x 440 x 320	115-225 x 300 x 270	26kg	20L	-

*minimum external height 210mm, maximum external height 320mm



Size 2

Unica Wall Safe

 **Cash Rating**
£6,000

 **Jewellery Rating**
£60,000



- Independently tested and certified to EN1143-1 Grade 0 by ICIM
- Insurance approved by the AiS
- High security wall safe with flush facia
- Designed to be set in reinforced concrete
- Option of key or electronic locking
- The electronic lock includes an emergency over ride key and external battery power point in case of lock out
- Removable shelf

Locking Options

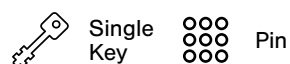

Model	External (HxWxD)	Internal (HxWxD)	Weight	Volume	Shelves
Size 1	270 x 390 x 200	245 x 365 x 120	21kg	11L	1
Size 2	340 x 460 x 240	315 x 435 x 160	30kg	22L	1
Size 3	480 x 420 x 280	455 x 395 x 200	42kg	36L	1

Oculto

 **Cash Rating**
£17,500

 **Jewellery Rating**
£175,000



- Recommended cash rating of up to £17,500
- 40mm thick stainless steel door
- External 10mm thick waterproof lid
- Designed to be set into reinforced concrete in the floor of a building
- Option of key or mechanical combination locking

Locking Options

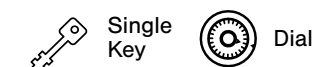

Model	External (HxWxD)	Internal (HxWxD)	Weight	Volume	Shelves
Oculto	435 x 305 x 285	245 x 260 x 267	25kg	19L	-



*The Sure Defence
against fire damage*

Fire Safes

Burton Fire Safes are The Sure Defence against fire damage, built to a Police Preferred Specification Secured by Design and offering a combination of fire and security protection for your valuables, documents, paper, USB's and data.

The Firesec range is insurance approved by the AiS for cash and jewellery cover ratings, independently attack tested to EN standards and suitable for storage of controlled drugs with active ingredients exceeding 500g. All our fire safe models are tested and certified to EN15659 LFS 60P by world renowned German certification body ECBS.

If you require fire protection for your safe, Burton Safes recommends you should only purchase products that have been independently tested and certified to these standards.



Firesec 4/60 Large

Firesec 4/60



Cash Rating
£4,000



Jewellery Rating
£40,000



Fire Rating 60 minute
Fire protection for paper



- Independently attack and fire tested to EN14450 S2 and EN15659 LFS 60P by ECB•S
- Insurance approved by the AiS
- Built to a Police Preferred Specification - Secured by Design
- 60 minute fire test at temperatures up to 900°C
- Option of key or electronic locking
- Suitable for storage of controlled drugs with active ingredients under 500g
- Height adjustable shelving
- Option of pullout shelves, hanging frame and lockable coffer in size XL - additional lead time and costs apply
- Base fixing
- Safe for Longer warranty does not include size XL

Locking Options



Single Key

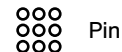

Pin



Model	External (HxWxD)	Internal (HxWxD)	Weight	Volume	Shelves
Large	670 x 480 x 460	510 x 330 x 300	103kg	50L	1
XL	1950 x 940 x 585	1760 x 800 x 390	545kg	549L	4

Add 20mm to external depth for handle, hinges and electronic lock on Large model and 55mm for XL model



Firesec 4/60 XL



Firesec 4/60 XL



Firesec 10/60



Cash Rating
£10,000



Jewellery Rating
£100,000



Fire Rating 60 minute
Fire protection for paper



- Independently attack and fire tested to EN1143-1 Grade 1 and EN15659 LFS 60P by ECB•S
- Insurance approved by the AiS
- Built to a Police Preferred Specification - Secured by Design
- 60 minute fire test at temperatures up to 900°C
- Suitable for storage of controlled drugs with active ingredients exceeding 500g
- Height adjustable shelving and internal coffer in sizes 2 and 3
- Option of pull-out shelves and hanging frames in size 4 additional lead time and costs apply
- Base fixing
- Safe for Longer warranty does not include size 4

Locking Options



Single Key



Dual Locking



Pin



Biometric



Dial

Model	External (HxWxD)	Internal (HxWxD)	Weight	Volume	Shelves
Size 1	490 x 480 x 445	330 x 330 x 290	101kg	31L	1
Size 2	750 x 555 x 550	*335 x 410 x 390	195kg	93L	1
Size 3	1100 x 555 x 550	*705 x 410 x 390	271kg	148L	1
Size 4	1950 x 940 x 585	1760 x 800 x 390	658kg	549L	4

Add 55mm to external depth for handle, hinges and electronic lock *Excludes internal coffer Height = 235mm



Firebrand



Cash Rating
£1,000



Fire Rating 60 minute
Fire protection for paper



- Independently fire tested and certified to EN15659 LFS 60P by ECB•S
- 60 minute fire test at temperatures of up to 900°C
- Batteries located externally in the event of power failure
- Removable tray in all sizes
- Removable shelf in sizes 2 and 3
- Base fixing

Locking Options



Pin

Model	External (HxWxD)	Internal (HxWxD)	Weight	Volume	Shelves
1	295 x 430 x 365	190 x 325 x 235	34kg	15L	-
2	490 x 360 x 425	380 x 260 x 295	44kg	29L	1
3	510 x 445 x 425	410 x 340 x 290	51kg	41L	1

Add an extra 20mm to external depth for handles, hinges and any lock



Firebrand XL



Cash Rating
£1,000



Fire Rating 60 minute
Fire protection for paper



- Independently fire tested and certified to EN15659 LFS 60P by ECB•S
- 60 minute fire test at temperatures of up to 900°C
- Electronic PIN code locking
- Batteries located externally so you are never locked out in the event of power failure
- Dead bolts secure the door, even if the hinges are cut off
- Removable drawer in each size
- Removable shelf in sizes 2 and 3
- Base fixing

Locking Options

Pin

Model	External (HxWxD)	Internal (HxWxD)	Weight	Volume	Shelves
1	970 x 565 x 450	785 x 425 x 300	147kg	100L	2
2	1255 x 710 x 580	1035 x 545 x 420	234kg	237L	2
3	1710 x 710 x 580	1490 x 545 x 420	370kg	341L	3

Add an extra 50mm to external depth for handles, hinges and any lock

Fire Resistant Filing Cabinets

Range options



Model 2



Model 3



Model 4

Fire Resistant Filing Cabinets



Fire Rating 60 minute
Fire protection for data



- Independently tested and certified to EN15659 LFS 60P by ECB•S
- Tested at temperatures of up to 900°C
- Choose from high security key or electronic PIN code locking
- Option to control each drawer individually with a high security cam lock
- Individual drawer latch means you can choose which drawers are locked by the central control system
- Drawers are suitable for both A4 and Foolscap files, each drawer can hold up to 40kg
- Anti-tilt device, means that only one drawer at a time can be opened
- Tactile rubber handles

Locking Options



Single Key Pin



Model	External (HxWxD)	Internal (HxWxD)	Weight	Volume	Shelves
2	825 x 545 x 655	250 x 390 x 500	110kg	48L	2
3	1165 x 545 x 655	250 x 390 x 500	150kg	48L	3
4	1500 x 545 x 655	250 x 390 x 500	210kg	48L	4

Add 40mm to external depth for handles and electronic lock





TESTED SOLD SECURE BRONZE - SILVER - GOLD



Tested and certified to Firearms cabinets SS302:2020 by Sold Secure
Police Preferred Specification – Secured by Design

Gun Safes & Cabinets

The Gun Safe range is suitable for shot guns and rifles and accommodates most models with scopes and silencers fitted. Securely store your guns in high security gun cabinets that are made to the Police Preferred Specification under the Secured by Design scheme.

These models are ideal to secure a gun collection, with high density foam gun holders and base, holders for cleaning rods and ammo belts, internal lockable ammo box and optional side shelf for other valuables. Furthermore, this range has a choice of locking options: single key, mechanical combination, electronic PIN, or biometric locking system.

Our Pioneer, Warden LFS and Gamekeeper models have been tested and certified to the Sold Secure Firearms Cabinets Standard SS302:2020 Bronze, Silver and Gold respectively.

We are proud to be first to achieve all 3 British test standards certified by Sold Secure which is owned by the Master Locksmith Association.



Warden LFS Gun Safe



Cash Rating
£6,000



Jewellery Rating
£60,000



- Independently tested to EN1143-1 Grade 0 and EN15659 by IMP
- Tested and certified to Firearms Cabinets SS302:2020 – Silver by Sold Secure
- Built to a Police Preferred Specification - Secured by Design
- Up to 30 minutes fire protection for paper
- Three way locking bolts
- Suitable for shotguns or rifles and will accommodate most scopes and silencers
- Foam gun holders
- Internal lockable ammo box
- High security key or electronic locking
- 6 Gun and 14 gun options
- Back and base fixing



Pioneer Gun Cabinet



Cash Rating
£1,000



Jewellery Rating
£10,000

- Tested and certified to Firearms Cabinets SS302:2020 Bronze by Sold Secure
- Built to a Police Preferred Specification - Secured by Design
- Lockable ammunition compartment
- Double-bitted key lock
- Suitable for both shotguns and rifles
- Foam gun holders and internal carpet
- 5 Gun and 10 gun options available
- Back and base fixing



Locking Options



Single Key



Locking Options



Single Key



Pin

Model	External (HxWxD)	Internal (HxWxD)	Ammo Box Internal	Weight	Guns
W 6	1650 x 460 x 450	1530 x 340 x 300	195 x 340 x 270	205kg	6
W 14	1650 x 880 x 450	1530 x 760 x 300	195 x 760 x 270	325kg	14

Model	External (HxWxD)	Internal (HxWxD)	Weight	Volume	Guns
P 5	1450 x 340 x 280	1300* x 335 x 245	45kg	119L	5
P 10	1450 x 535 x 320	1300* x 530 x 285	75kg	218L	10

*Excluding the height of ammo box





Gamekeeper Gold



Cash Rating
£10,000



Jewellery Rating
£100,000



- Independently tested to EN1143-1 Grade 1 by ECB•S
- Tested and certified to Firearms Cabinets SS302:2020 – Gold by Sold Secure
- Insurance approved by the AiS
- Built to a Police Preferred Specification - Secured by Design
- Three way locking bolts
- Suitable for shotguns or rifles and will accommodate most scopes and silencers
- Foam gun holders
- Internal lockable ammo box on 9 gun model
- High security key or electronic locking
- 5 Gun and 9 gun options
- Back and base fixing
- Cleaning rod holder included



Locking Options



Single Key



Pin

Model	External (HxWxD)	Internal (HxWxD)	Weight	Volume	Guns
Gold 5	1400 x 450 x 440	1300 x 350 x 320	365kg	146L	5
Gold 9	1550 x 650 x 440	1450 x 550 x 320	520kg	255L	9

Add 50mm to external depth for handle and hinges. Ammo box on Gold 9 reduces internal height by 195mm





*Safes for hotels,
guest houses, Airbnbs,
holiday homes and villas!*

Hotel & Guest Safes

The Hotel Safe range has a simple locking system that can be used with complete ease and by multiple users. These models have display screens, back lit buttons and audible sounds to easily guide users through their operation.

The guests can choose a 3-6-digit code; few enough digits to prevent guests forgetting, whilst also being secure. In the case of a guest forgetting or, if the batteries in the lock run out: this range features an override emergency key and master code.

This range of products can also be ideal for student accommodation, Airbnb and domestic use.

Hotel Standard



Cash Rating
£1,000



Jewellery Rating
£10,000

- Economical unit with simple guest operation
- Users choose their own 3-8 digit code to open the lock.
- You can reset the code anytime the safe is open.
- You are provided with an emergency over-ride key for this safe – Please do not keep the keys inside the safe.
- Bleepers and LED lights to confirm actions
- Back and base fixing

Locking Options



Pin

Model	External (HxWxD)	Internal (HxWxD)	Weight	Volume	Shelves
1	200 x 310 x 215	195 x 305 x 120	6kg	7L	-

Add 25mm to external depth for keypad

Hotel Drawer



Cash Rating
£1,000



Jewellery Rating
£10,000

- Blue backlit keypad with motorised locking
- Users choose their own 4 - 6 digit code
- Features keyed alike emergency key and master code
- Audit trail of last 100 openings
- Back and base fixing

Locking Options



Pin

Model	External (HxWxD)	Internal (HxWxD)	Weight	Volume	Shelves
1	200 x 350 x 410	130 x 260 x 340	14kg	11L	-

Add 15mm for the keypad and handle

Hotel Primo



Cash Rating
£1,000



Jewellery Rating
£10,000

- Guests choose their own 3-6 digit code
- Backlit keypad and interior carpet
- Will accommodate most laptops and tablets
- Audit trail facility
- Features keyed alike emergency key and master code
- Battery level indicator with a low consumption motor
- USB model features an internal USB charging point
- Back and base fixing

Locking Options



Pin

Model	External (HxWxD)	Internal (HxWxD)	Weight	Volume	Shelves
Hotel Primo	200 x 420 x 370	190 x 415 x 315	9kg	24L	-
Hotel Primo USB	200 x 420 x 370	190 x 415 x 315	9kg	24L	-

Add 15mm to external depth for keypad

Hotel Pop Up



Cash Rating
£1,000



Jewellery Rating
£10,000

- Blue backlit keypad with motorised locking
- Pop up lid with internal carpet
- User chooses own 4 - 6 digit code
- Will accommodate standard sized laptops
- Features keyed alike emergency key and master code
- Audit trail of last 100 openings
- Back and base fixing

Locking Options



Pin

Model	External (HxWxD)	Internal (HxWxD)	Weight	Volume	Shelves
1	145 x 400 x 350	75 x 395 x 345	12kg	10L	-

Add 15mm for the keypad and handle



High security measures to safeguard your cash.

Retail Safes

Deposit safes have become a necessity for businesses as hold up situations and internal fraud have become an increasing threat. Some of these safes have been independently tested and certified to EN1143-2 by ECB • S.

Having a separate deposit drawer means staff can deposit cash/valuables without having access to the main safe.

Both the drawer and the safe door are fitted with separately operated high security locks. These models have optional locking including mechanical combination, electronic PIN or advanced biometric locking systems.



Till Safe

 **Cash Rating**
£4,000 or £10,000

 **Jewellery Rating**
£40,000 or £100,000

- Independently tested and certified to EN14450 S2 or EN1143-1 Grade 1
- Insurance approved by the AiS
- Built to a Police Preferred Specification - Secured by Design
- Grade 1 Till Safe tested and certified to EN15659 LFS30P providing 30 minutes fire protection for paper
- Designed for storage of till drawers
- Store a minimum of 4 drawers in each model
- 2 different security levels to suit your requirements
- High security electronic locking on S2, option of key, electronic or biometric locking on the Grade 1
- Back and base fixing

Locking Options

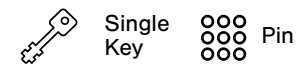

Model	External (HxWxD)	Internal (HxWxD)	Weight	Volume	Shelves
S2 Till	510 x 550 x 500	430 x 470 x 400	47kg	80L	3
G1 Till	840 x 650 x 550	782 x 574 x 420	289kg	189L	2

Add 55mm to external depth for handle on G1 Till



Cashguard Vehicle Safes

- Ideal for use in vans / lorries on delivery rounds
- A range of deposit slots and security levels to suit your requirements
- Base plates attach to the vehicle and the main safe body is locked into these
- The safe has two locks, one for the base plate and one for the safe door
- The two locks are on different keys.
 - This allows drivers to move the safe from the base plate without having access to the contents of the safe

Locking Options



Model	External (HxWxD)	Internal (HxWxD)	Slot Size	Weight	Volume
Mini	255 x 165 x 150	210 x 160 x 145	90 x 32	5kg	4L
Cashguard	380 x 205 x 150	350 x 200 x 120	150 x 90	15kg	8L



Teller Deposit Safe

 **Cash Rating**
Up to £3,000

- Choice of deposit methods and trap sizes to suit your requirements
- Size 1 V Trap deposit via a front loading V Trap system
- Size 1 Rotary deposits via a top loading rotary drum
- Option of key, electronic or biometric locking*
- Automatic slam locking system**
- Back and Base fixing

*Electronic and biometric locking not available on the Mini Teller

**If fitted with the Burton Duo swing lock or the Kaba Axessor

Locking Options

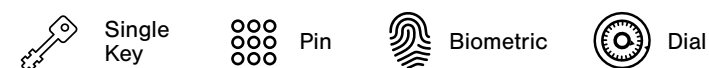

Model	External (HxWxD)	Internal (HxWxD)	Slot Size	Weight	Volume
Mini Teller	305 x 205 x 255	295 x 195 x 180	20 x 135 x 200	15kg	10L
Size 1 Rotary	510 x 355 x 355	330 x 345 x 275	255 x 105 x 120	40kg	31L
Size 1 V Trap	505 x 355 x 355	220 x 345 x 275	45 x 265 x 190	40kg	21L

Add 45mm to external depth for handle on sizes 1 and 2



Eurovault Aver Deposit Grade 1

 **Cash Rating**
£10,000

- Independently tested and certified to EN1143-2 Grade 1 by ECB-S
- Insurance approved by the AiS
- Built to a Police Preferred Specification - Secured by Design
- Drawer deposit means staff can deposit without accessing the main safe
- Option of key, electronic or biometric locking for both main door and deposit drawer
- Time delay, time windows and duress features available with electronic lock upgrade
- Base fixing

Locking Options

Any lock alterations must conform to EN1300 Class A

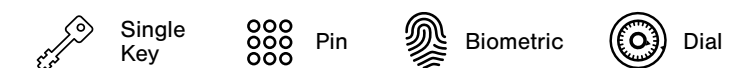

Model	External (HxWxD)	Internal (HxWxD)	Max Deposit Size	Weight	Volume	Shelves
Size 1	670 x 650 x 550	455 x 573 x 423	100 x 500 x 120	190kg	110L	-
Size 2	1040 x 650 x 550	816 x 573 x 423	100 x 500 x 120	270kg	298L	2

Add 55mm to external depth for handle



High Security Deposit Safe Grade 2

 **Cash Rating**
£17,500

- Independently tested and certified to EN1143-2 Grade 2 by SBSC
- Insurance approved by the AiS
- Built to a Police Preferred Specification - Secured by Design
- Deposit drawer means staff can deposit without accessing the main safe
- Deposit drawer is secured by a high security key lock
- Option of key, electronic or biometric locking on the main door
- Rear facing/through wall deposit available to order
- Base fixing



Locking Options

Any lock alterations must conform to EN1300 Class A.



Model	External (HxWxD)	Internal (HxWxD)	Max Deposit Size	Weight	Volume	Shelves
Size 1	770 x 565 x 540*	400 x 390 x 330	25 x 320 x 100	416kg	51L	-
Size 2	970 x 565 x 540*	600 x 390 x 330	25 x 320 x 100	485kg	77L	-

Add 55mm to external depth for handle *Add 20mm to external width for hinges



High Security Deposit Safe Grade 3

 **Cash Rating**
£35,000

- Independently tested and certified to EN1143-2 Grade 3 by SBSC
- Insurance approved by the AiS
- Built to a Police Preferred Specification - Secured by Design
- Deposit drawer means staff can deposit without accessing the main safe
- Deposit drawer is secured by a high security key lock
- Option of key, electronic or biometric locking on the main door
- Rear facing/through wall deposit available to order
- Base fixing



Locking Options

Any lock alterations must conform to EN1300 Class B.



Model	External (HxWxD)	Internal (HxWxD)	Max Deposit Size	Weight	Volume	Shelves
Size 1	770 x 565 x 540*	400 x 390 x 330	25 x 320 x 100	420kg	51L	-
Size 2	970 x 565 x 540*	600 x 390 x 330	25 x 320 x 100	525kg	77L	-

Add 55mm to external depth for handle *Add 20mm to external width for hinges



SAFE LOCKS

Burton Safes work with all of the world's major safe lock manufacturers to bring you a wide choice in locking solutions and access control for your safes and vaults.

Below are some of the more popular models but please enquire if you have a specific need and we will find a lock to suit your needs and budgets.

We have strategic partnerships with **Insys** and **Kaba**, ensuring that we can provide solutions for the most demanding of commercial environments - CvIT, banking and large retail estates.

CONTACT OUR COMMERCIAL TEAM FOR MORE INFORMATION



enquiries@burtonsecurity.com
+44 (0) 1484 663388

Descriptions of the safe lock terminology can be found on page 69.

What Burton Safes recommend		Burton Duo Light	Burton Pulse	Burton Bio	Kaba Connect	Axessor USB	Axessor IP	LaGard 701	LaGard 703	CombiLock Pro	Elostar Master	Twinlock Business	Paxos
TYPES OF CODES	No. of User Codes	1	1	10	10	18	36	1	28	9*	99	99	95
	No. of Manager Codes	1	1			2	4	1	1	1	1	1	Multiple levels
	No. of Master Codes			1	1	1	1	1	1	1	2 or 3	2	Multiple levels
	Dual User			YES	YES	YES	YES	NO	YES	YES	YES	YES	YES
	Courier Code					YES	YES	NO	YES	YES	YES	YES	
	Duress Code				YES	YES	YES	NO	YES	YES	YES	YES	YES
One Time Code										YES	YES		
LOCK FEATURES	Time Delay	YES	YES	YES	YES	YES	YES	NO	YES	YES	YES	YES	YES
	Time Lock			YES	YES	YES	YES	NO	YES	YES	YES	YES	YES
	Audit Trail			YES	YES	YES	YES	NO	YES	YES	YES	YES	YES
	Biometric Option			YES	YES	via I/O box	via I/O box					YES	via I/O box
MECHANICAL FEATURES	Remote Programming						YES				YES	YES	YES
	I/O box					YES	YES			YES	YES	YES	YES
	Redundant System										YES	YES	YES
Multi Lock Option											YES	YES	
TYPE OF LOCKING	Swing Bolt	YES	YES					YES	YES		YES	YES	
	Dead Bolt	YES	YES		YES			YES	YES		YES	YES	
	Motorised Bolt					YES	YES			YES	YES		YES
Lock Grade	B	B	B	B	B	B	B	B	B	B	B/C/D	B/C/D	

Kaba Connect user details are per lock.

*Optional upgrade to 50 users on request

Burton Duo Fingerprint Lock

ScanLogic Basic
FPC-1808-II (VdS)

To be used with locks
EL-0601, EL-0701, EL-0901

Specifications

Rated voltage: DC 9V
Working temperature: -25° ~ 60°
Humidity during use: <90%.
Code length: 6 digits

Only suitable for indoor use

Safe locks certified in accordance with EN1300 are not permitted to be opened by fingerprints only (without additional code entry).

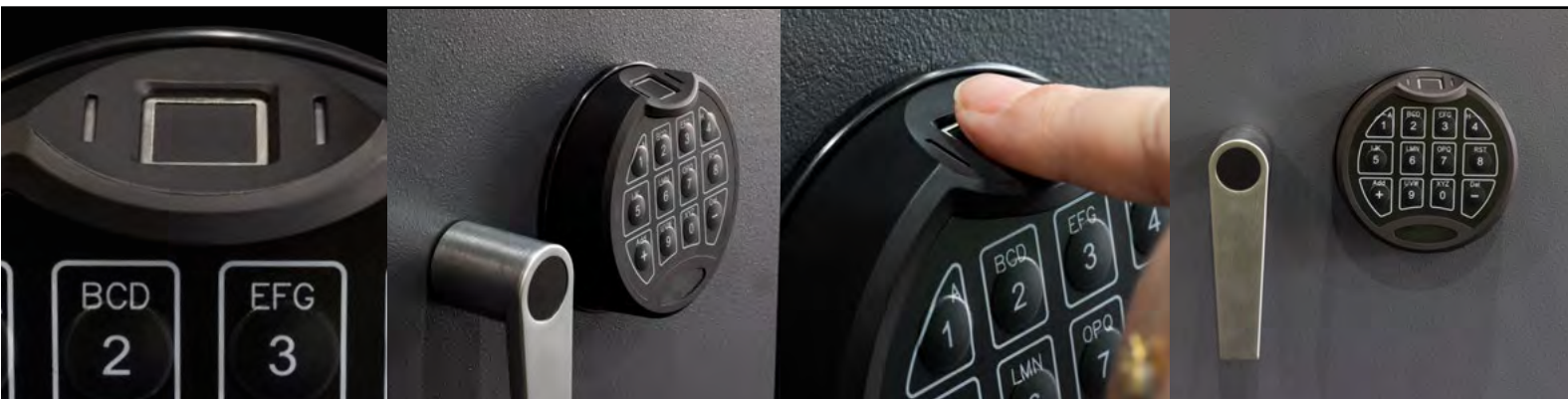

New featured product Dual fingerprint and code lock upgrade available on all graded safes



Important

- Always carry out programming when the lock is open and safe door is open.
- Before closing the safe door, make sure that all the programming is correct.
- Check a new code at least 3 times before closing and locking the door to ensure that the code has been changed correctly.
- The system does not allow the master code, the manager code, and the user code to be set at six zeros (0-0-0-0-0-0) or six nines (9-9-9-9-9-9).
- To save battery power, the system switches to standby mode if no button is pressed within 10 seconds. Standby mode is indicated by two short beeps. Input processes that have not yet been completed must be repeated completely.
- Do not allow your personal code to be spied on. When entering the code, always cover the keypad as well as possible so that no one can see which numeric key you are pressing.

At Burton Safes we have a huge range of locking options.

See page 66 for full details on our recommended models.

With the original design concept of being 'Easy to use' the KABA Axessor USB delivers a huge range of functions, via a simple visual input unit. One interesting feature is the DURESS function. This facility enables the lock to be connected to an alarm system, activating a silent signal to a remote monitoring station or to the Police when the user is under 'duress' by entering a slightly different code – this can also trigger a time delay if programmed.



Kaba Axessor USB

- Duress Code
- 18 Users
- Time Delay
- Time Lock Periods
- Battery Powered
- Clear Display
- Dual / 4 Eye Function
- Audit Trail of 10,000 events
- Alarm Connection
- Wrong Try Lockout (4 false attempts)
- Tamper Function
- Holiday Periods

The KABA Axessor USB is one of the most efficient and reliable locks on the market – suitable for domestic and commercial use, contact the office for a full description and to discuss your locking needs.

Insys flex ID

A flexible locking system for security containers like gun cabinets, safes, secure cabinets or entry and access doors. Access takes place contactless via RFID card or RFID tag. Stand alone or with a state of the art software system, Elocomm, for programming, control and audit. The Flex brings full access control functionality to your secure storage needs.

- High-quality motor lock and compact RFID reader unit
- Easy, quick opening via RFID card/RFID tag
- Easy enrolment of additional users without configuration software and keypad
- Adding of up to 99 additional cards/tags possible
- Manipulation blocking and automatic locking
- Emergency power supply
- Time delay, dual code and external release/blocking (only EloStar® flexID multi)



Safe Lock Terminology

Users – Unique individual's code that can be controlled by a "Master" or "Manager".

Dual user - If Dual user mode is set in your safe it will require two different user codes to open the lock. This means two people will need to be with the safe to open it, this helps prevent internal fraud.

Courier Code - Courier codes are generally used by CVIT (cash and valuables in transit) to bypass any time delay settings within the safe and sometimes the time windows.

Duress Code – A duress code is a covert distress signal. When you input the code, a silent alarm will be sent to the Police or a monitoring station in the event that you are forced to open your safe.

The Duress code can still open the lock to the safe.

One Time Code - OTC (one-time code) is a code that can be created and passed to a user to open the safe – once they have used that code it will become invalid. These are often used by CVIT (cash and valuables in transit) operators.

Time Delay – A time-delay is a setting that delays the unlocking of the lock by a user-definable period. After entering your code you wait the set time before you enter your code a second time to open the safe.

Time Lock – Weekly programmable timer installed inside, which allows the user to set time intervals that control when the safe opens – i.e. you can open the safe in-between 9am and 5pm but not outside of those hours even if you know the code.

Audit Trail - This logs every event within the safe – Which user opened and closed the safe, at what time. It will never show the code, just the user number i.e. User 2 opened the safe at 2:30pm 30/08/2018.

Biometric Option – Fingerprint controlled security lock. These locks come with the option of fingerprint access, code access or both.

Swing Bolt - Once a correct code is entered, the lock is released, allowing the boltwork to move when turning the handle.

Dead Bolt - Once a correct code is entered, the user has to manually move the locking bolt, usually by turning the keypad.

Motorised Bolt - Once a correct code is entered, the lock moves the locking bolt via an electronic motor.





THE SURE DEFENCE

*Let us help solve
your key problems!*

Key Safes and Key Management

The Key Safe range is the perfect security solution for securing and storing keys. This range includes Keyguard allowing authorised access to carers, cleaners, workmen, dependents, holiday lets, and key cabinets designed for use in showrooms, garages, universities, schools and large commercial sites.

We provide products that answer a variety of requirements: UK Police Preferred Specification under the Secured by Design scheme, and the Keyguard Digital XL is certified to LPS1175 (Issue 8) A5.

LPS1175 Issue 8 is an independent attack test certification. A tool list is selected and then time given to withstand a physical attack. Keyguard XL is the first key safe to achieve this level.

LPCB is part of the BRE Group, the world renowned certification and testing facility who test and certify products to the very latest attack methods.



High Security Solution for storing keys



Keyguard Digital XL



- The world's first key safe to be successfully certified to LPS1175 Issue 8
- Police Preferred Specification
- Independently tested and certified to LPS1175 Issue 8 A5
- Permanent, lightweight, weather-resistant cover provided. This doubles as a fixing template for quick and easy install
- Bright numbers and indicators for ease of use
- Internal key hook
- Over 4,000 possible code combinations
- Code can be changed multiple times
- Allows storage for multiple keys or key cards
- Fixings are provided
- Also certified for fixing to rendered walling
- 5 year warranty



Locking Options

OOOO Pin



LPS1175: Issue 8
Cert No: 1000m



Police Preferred Specification

Model	External (HxWxD)	Internal (HxWxD)	Weight
KG XL	160 x 95 x 55	70 x 50 x 20	2.6kg



LPS1175: Issue 8
Cert No: 1000m

Secured by Design



Police Preferred Specification

LPCB is an independent attack test certification. A tool list is selected and then time given to withstand a physical attack. Keyguard XL is the first key safe to achieve this level.

LPCB is part of the BRE Group, the world-renowned certification and testing facility in the UK, who test and certify products to the very latest attack methods.

Certified for fixing to rendered walling by multiple fixing types, available to all installers.

With Secured by Design accreditation the Digital XL meets Police Preferred Specification.

**POLICE PREFERRED
HIGH SECURITY
KEY SAFE**

New A5 LPCB attack certification



CK/E 40

Heavy Duty Key Cabinets

- Top quality range of key cabinets that offer a high level of security
- Ideal for use in car showrooms, garages, universities, schools and large commercial sites
- 8mm solid steel door and 3mm steel body
- High security, 8 lever key lock or electronic PIN code lock
- Electronic version features a flush keypad, an emergency key and an external power point in case of lock out
- Door secured by two solid locking bolts

Locking Options

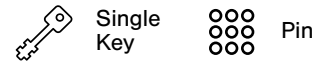

Model	External (HxWxD)	Internal (HxWxD)	Weight	Key Hooks
CK/E 40	470 x 360 x 140	460 x 350 x 120	25kg	40
CK/E 120	470 x 360 x 140	460 x 350 x 120	27kg	120



KG74

KG Keyguard Key Safes

- Range of economical key safes
- Ideal for use in car showrooms, garages, universities, schools and large commercial sites
- 4mm Solid steel door and 2mm steel body
- Electronic PIN code - 1 user and 1 master code
- Supplied with emergency override keys in case of lock out
- Height adjustable numbered key racks
- Key tags supplied
- Prepared for wall mounting

Locking Options

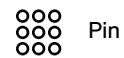

Model	External (HxWxD)	Internal (HxWxD)	Weight	Key Hooks
KG27	360 x 300 x 120	350 x 290 x 40	9kg	27
KG74	450 x 360 x 120	440 x 350 x 65	14kg	74
KG138	660 x 420 x 120	650 x 410 x 65	19kg	138

Add 10mm to the external depth to include the keypad



IKMS Intelligent Key Management System



IKMS

- 7" Full color, touch screen
- Software built inside the Android system
- Face recognition, fingerprint, PIN, and user card access to each key
- Standalone plug & play solution with advanced RFID technology
- Module replaceable key slots
- Report export by USB or Email
- Supports English, Germany, French, Polish, Japanese, Russian
- Standalone or web version (optional)
- Cloud management and remote control (Optional)

Locking Options



Model	External (HxWxD)	Weight	Key Hooks
IKMS	380 x 570 x 180	30kg	26



Remote Key Safe



The Critical Electronic Alarm Safe manufactured by Burton Safes provides remotely controlled and external key access to keys and critical data during an emergency situation. Providing Rescue forces, such as the fire brigade, ambulance and the police with access in case of an emergency.

- Open remotely via connection to the built-in electronic strike.
- High security 7 lever slam lock included for key access.
- Built in LED indicator lights up when opened remotely so that emergency services know when to open the door.
- Stainless steel pull handle.
- Powder coated finish as standard.
- Option to order in any available RAL colour. (Subject to minimum order quantity)

Locking Options



Model	External (HxWxD)	Internal (HxWxD)	Weight	Key Hooks
RKS	190 x 250 x 120	150 x 170 x 100	6.5kg	3

Measurements including flange



Additional info:



1 Flange

Flange at the front of safes to conceal damage and seal when cutting out Wall apertures.



2 Fixing Holes

Complete with 3/8" fixing holes in the sides for bolting into the wall.



1 Micro-switch

An optional micro-switch can be fitted to trigger a remote alarm when the door is opened.



POLICE PREFERRED



GARAGE GUARD

Approved to Sold Secure Silver

Garage & Door Security

We are proud to offer the new Guard range of products designed and Made In Yorkshire by our own in-house engineering team. The Guard range provides a heavy duty visual and physical deterrent for protecting your home and business from burglary.

With an average garage contents value of £1,500. Security for garage's often gets overlooked.

Our new Garage Guard protects up and over garage doors. This heavy duty solution is certified to Sold Secure Silver the only product of its type to pass this attack test and holds Police Preferred Specification.

Also available in the range is internal protection for roller shutters and garage doors, internal drop bars for reinforced security and a range of hasp locks for securing gates, sheds and doors.

Perfect for helping to secure your bicycles, motorcycles, e-bike and scooters from theft.



Garage Guard

- Tested and certified to Domestic Security Silver by Sold Secure
- Police Preferred Specification
- British made by Burton Safes Engineering
- Surface mounted to concrete
- Stainless steel anti-drill padlock
- All fixings supplied
- Available in Black



Model	External (HxWxD)	Weight
Garage Guard	135 x 230 x 260	3kg



Hasp Guard

- Perfect security addition for a shed, cellar or garage door
- Constructed from 5mm thick laser cut steel
- British made by Burton Safes Engineering
- Hard wearing powder coated finish
- Available in 3 length sizes
- Can mix and match sizes
- Fixings included

*padlock sold separately

Model	External (HxWxD)	Weight
Size 1	50 x 100 x 40	1kg
Size 2	50 x 200 x 40	1kg
Size 3	50 x 300 x 40	1kg



Shutter Guard

- Suitable for garage and roller shutter doors
- British made by Burton Safes Engineering
- Precision laser cut steel
- Surface mounted to concrete
- All fixing supplied

Model	External (HxWxD)	Weight
Shutter Guard	130 x 115	2kg



Force Guard

- Drop in security bars, suitable for shed, garage, and internal doors
- British made by Burton Safes Engineering
- Available in 3 length sizes
- Steel locking bar with capped ends
- Hard wearing powder coated finish

Model	External (HxWxD)	Weight
Size 1	50 x 810 x 25	1kg
Size 2	50 x 1010 x 25	1kg
Size 3	50 x 1210 x 25	1kg



Disc Padlock

- Anti-drill disc padlock
- Sold Secure tested
- 70mm Disc padlock
- Anti-drill plate on cylinder
- Key retained in unlocked position
- Stainless steel lock body

**Our most
Iconic Safes**

Design your Amario Lux



**SECURITY HAS
NEVER LOOKED SO GOOD**

Elegance and timeless styling meets modern technology

Burtonsafes.Design

**Elegance and security designed for
the protection of your valuables.**

The .Design Range from Burton Safes offers our clients the highest level of security, engineered to the most detailed level of precision. With over 30 years' experience providing global security solutions, we have built a reputation around luxury, security, integrity and customer service.

With Over 40 Safes for you to design and perfect your own unique style **Burtonsafes.design** has been created to help you choose your perfect security solution and design your own perfect unique safe.

We believe jewellery is for wearing and enjoying. When you are not, we want to help you protect it with the ultimate experience.

We advise choosing the highest grade safe possible to protect your jewellery, gold, watches, cash and valuables from criminals. Each of our designer safes has been attack tested and approved to European standards to meet insurance cover recommendations.

Our safes are also approved and registered with the AiS (Association of Insurance Surveyors) and meet the Secured by Design Police Preferred Specification for your peace of mind.

Visit **Burtonsafes.design** today and start creating your safe with elegance and security designed by you for you, for the protection of your valuables.

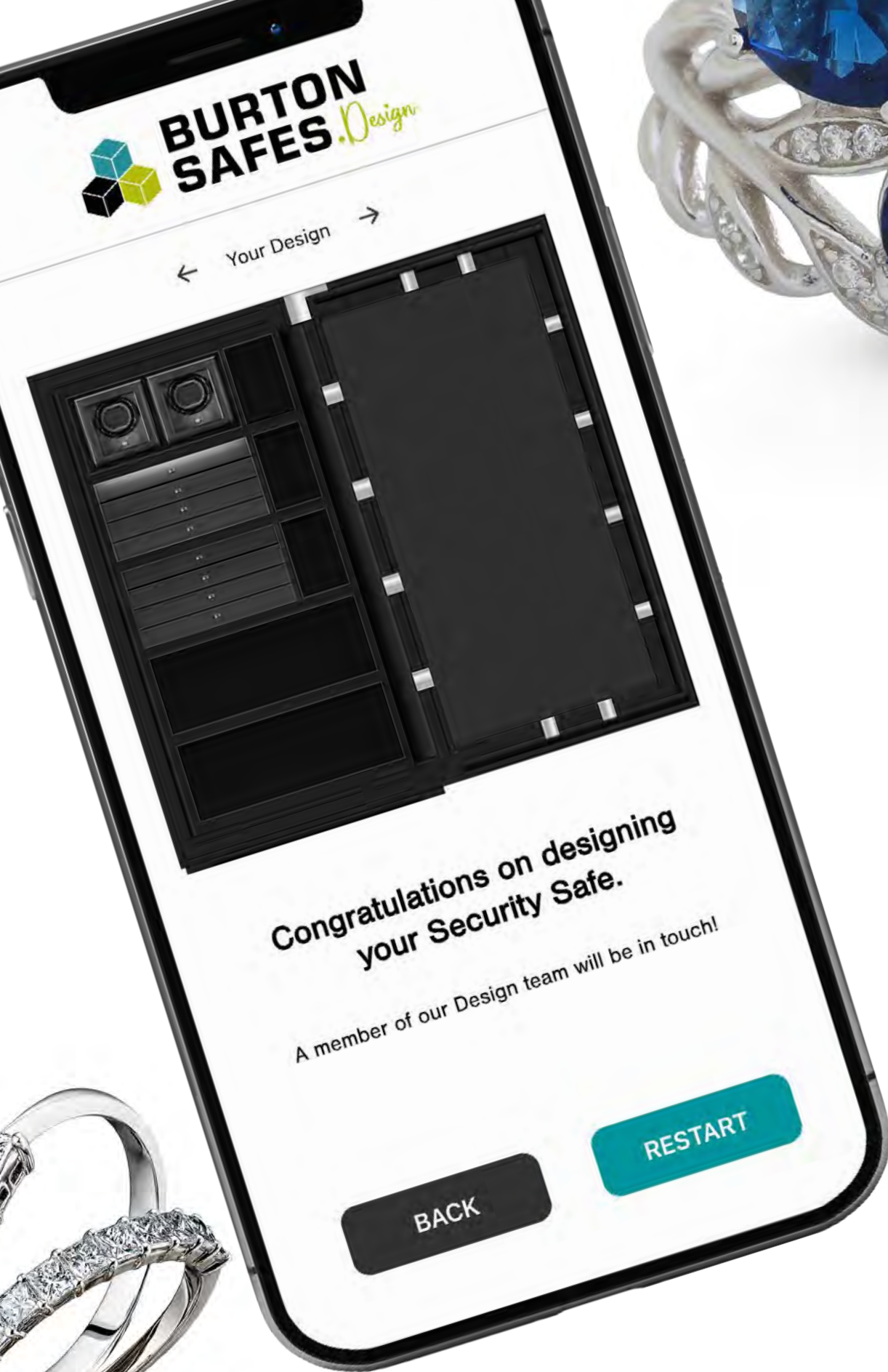

Burtonsafes.design **FREE APP!**

Burtonsafes.design has been created to help you choose your perfect security solution and design your own perfect unique safe.

We believe jewellery is for wearing and enjoying. When you are not, we want to help you protect it with the ultimate experience.

Safes created for your own personality and lifestyle

Over 40 Safes for you to design and perfect your own unique style



ARES

£4,000 Cash Rating
£40,000 Jewellery Rating



Electronic Lock

Certified to EN14450 - Grade S2 by ECB • S

Italian style designer safe range with aluminium handle.

Safe Colour RAL9016 White

SIZE 1

External dimensions

280 × 435 × 350

Internal dimensions

230 × 380 × 240

Weight

48KG

SIZE 2

External dimensions

635 × 485 × 450

Internal dimensions

575 × 430 × 350

Weight

111 KG

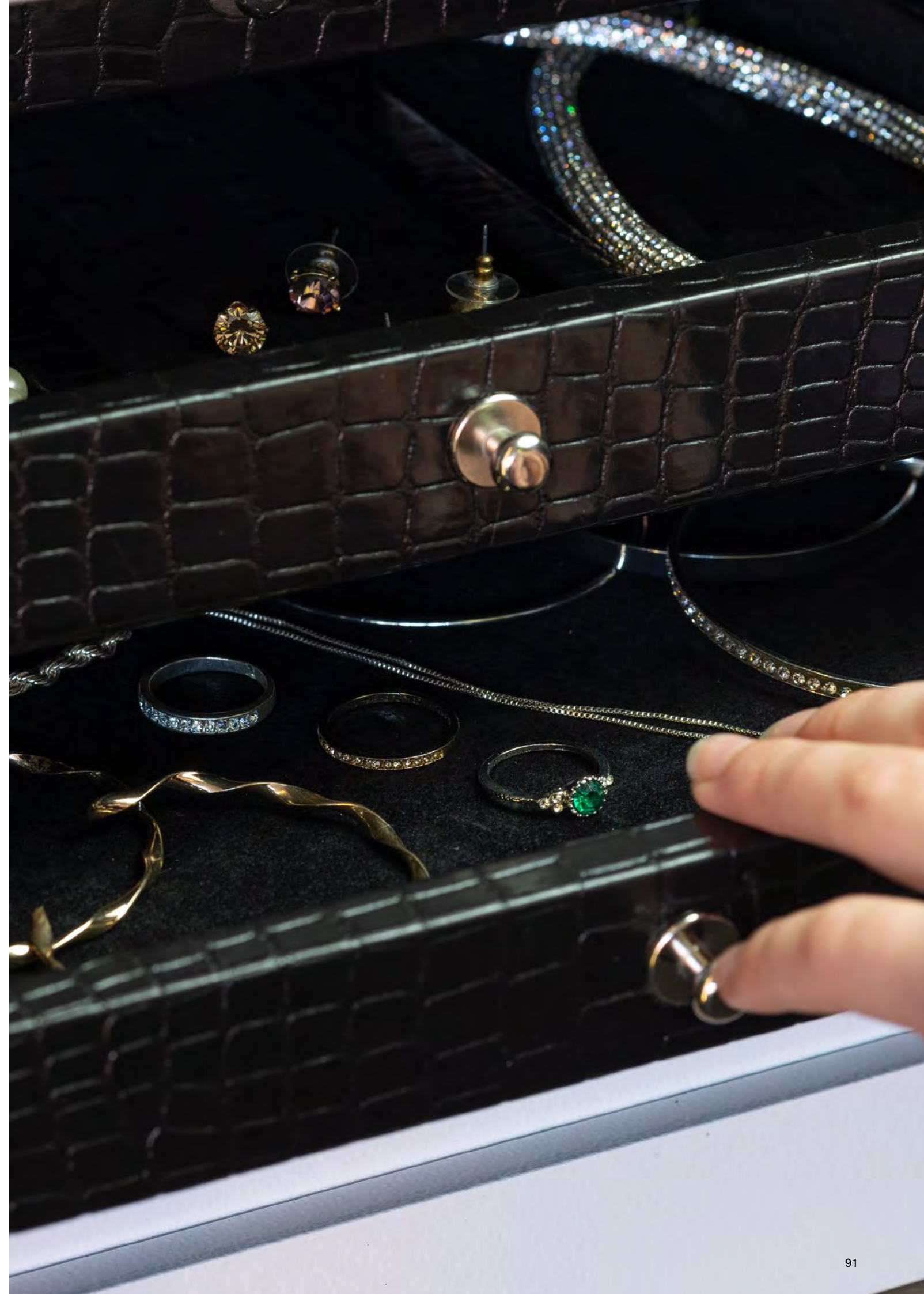
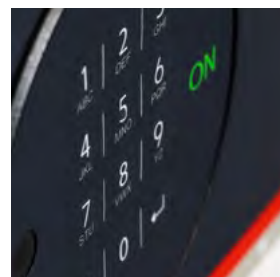
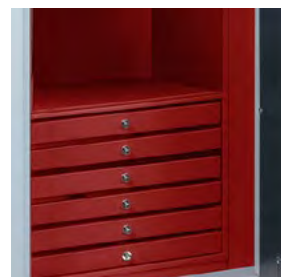

Choose a Module for your Valuables

Ares Size 1

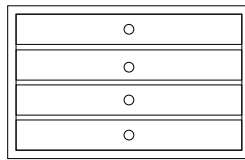

4 drawers

Ares Size 2

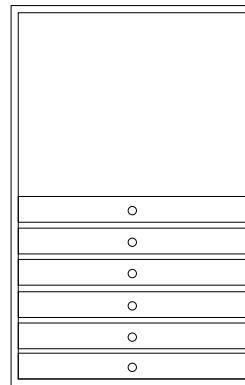

Open space and 6 drawers

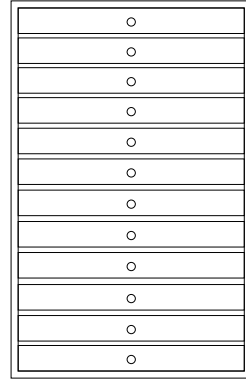

12 drawers

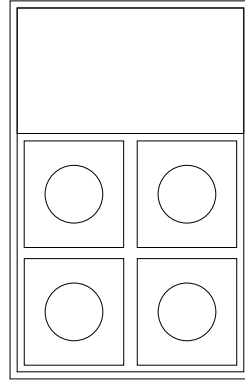

Open space and 4 watch winders

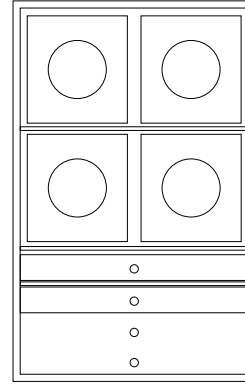

4 watch winders and 4 drawers

Your safe can be equipped with modules including drawers, watch winders. Hand crafted in Italy and covered with eco-leather. Available in 21 different colours.

Choose your Jewellery Trays

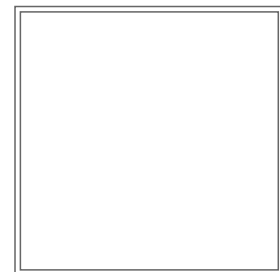

Plain

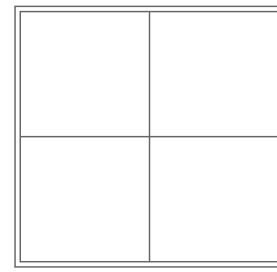

Four squares

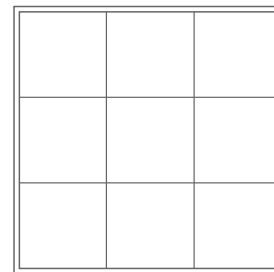

Nine squares

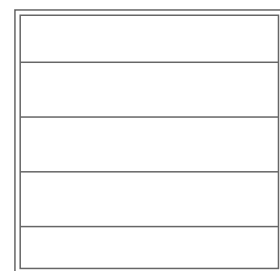

For necklaces

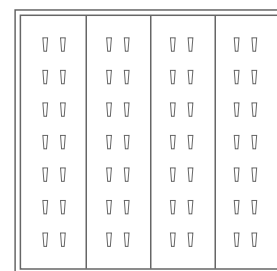

For rings

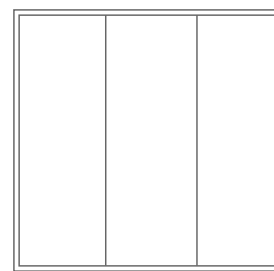

For watches

The drawers are internally covered with precious velvet. Customise with a choice of 17 colours.

Colour is a power which directly influences the soul

Module Outside Faux Leather



Drawer Velvet



Safe Colour



ARES Design

B R I X I A *uno*

£10,000 Cash Rating
£100,000 Jewellery Rating
Certified to EN1143-1 Grade 1
(Uno) by ECB•S

AVAILABLE IN 6 SIZES

Safe Colour

RAL9016 White - RAL9004 Black

Modules

Four Drawers (Led) - Four Drawers
2 Watch Winders - Open Storage Space

Module outside faux leather

Available in 21 different colours

Jewellery Trays

Plain - Four Squares - Nine Squares
For Necklaces - For Rings -For Watches

Velvet lining

Customise with a choice of 17 colours



Electronic Lock



B R I X I A *TRE*

£35,000 Cash Rating
£350,000 Jewellery Rating
Certified to EN1143-1
Grade 3 (Tre) by ECB•S.

AVAILABLE IN 8 SIZES

Safe Colour

RAL9016 White - RAL9004 Black

Modules

Four Drawers (Led) - Four Drawers
2 Watch Winders - Open Storage Space

Module outside faux leather

Available in 21 different colours

Jewellery Trays

Plain - Four Squares - Nine Squares
For Necklaces - For Rings -For Watches

Velvet lining

Customise with a choice of 17 colours



Electronic Lock

BRIXIA^{uno}

Available in 6 sizes

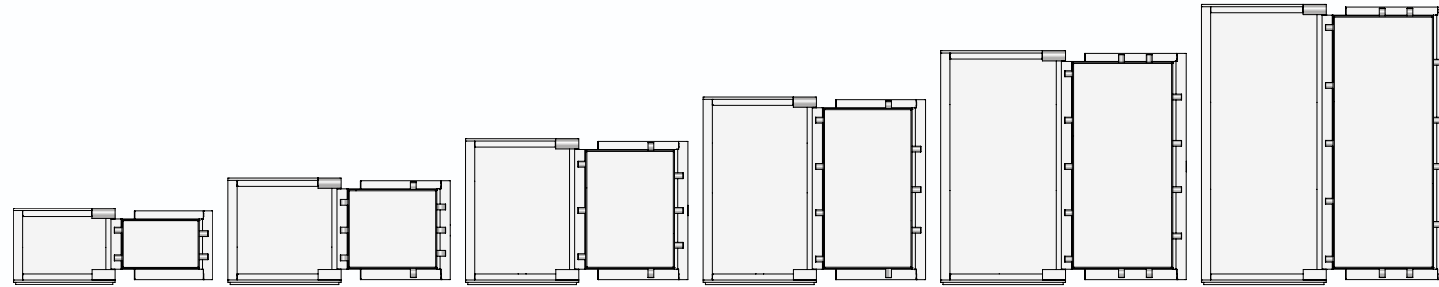

SIZE 1	SIZE 2	SIZE 3	SIZE 4	SIZE 5	SIZE 6
External dimensions 330 x 440 x 430	External dimensions 460 x 490 x 430	External dimensions 630 x 490 x 430	External dimensions 810 x 490 x 430	External dimensions 1010 x 540 x 480	External dimensions 1210 x 540 x 480
Internal dimensions 250 x 360 x 295	Internal dimensions 380 x 410 x 295	Internal dimensions 550 x 410 x 295	Internal dimensions 730 x 410 x 295	Internal dimensions 925 x 460 x 345	Internal dimensions 1125 x 460 x 345
Weight 85 KG	Weight 110 KG	Weight 125 KG	Weight 145 KG	Weight 200 KG	Weight 220 KG

BRIXIA^{TRE}

Available in 8 sizes

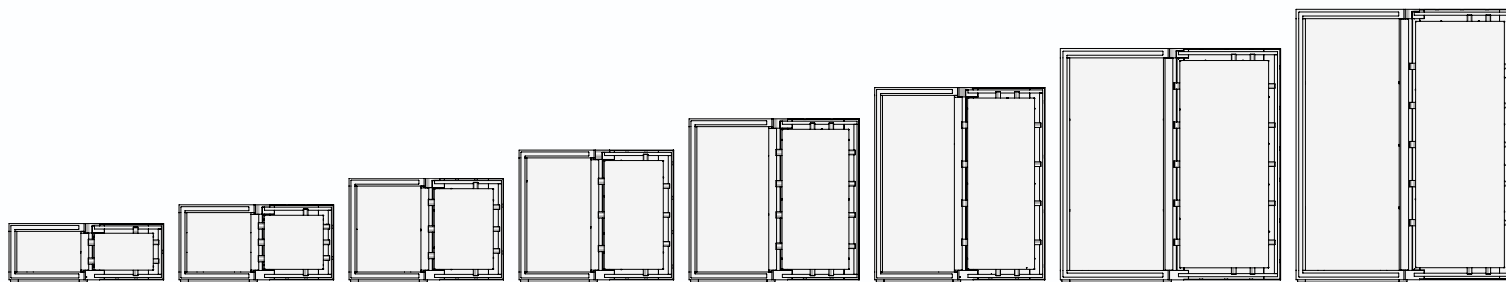

SIZE 1	SIZE 2	SIZE 3	SIZE 4	SIZE 5	SIZE 6	SIZE 7	SIZE 8
External dimensions 375 x 510 x 480	External dimensions 495 x 510 x 480	External dimensions 665 x 510 x 480	External dimensions 845 x 510 x 480	External dimensions 1045 x 560 x 530	External dimensions 1245 x 560 x 530	External dimensions 1495 x 720 x 620	External dimensions 1745 x 720 x 620
Internal dimensions 260 x 410 x 300	Internal dimensions 380 x 410 x 300	Internal dimensions 550 x 410 x 300	Internal dimensions 730 x 410 x 300	Internal dimensions 930 x 460 x 350	Internal dimensions 1130 x 460 x 350	Internal dimensions 1360 x 600 x 430	Internal dimensions 1610 x 600 x 430
Weight 160 KG	Weight 195 KG	Weight 235 KG	Weight 285 KG	Weight 380 KG	Weight 435 KG	Weight 670 KG	Weight 730 KG



Modules

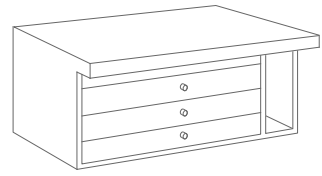

Four Drawer (Lid)

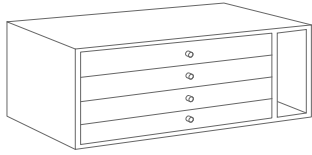

Four Drawer

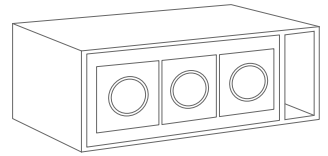

Watch Winders

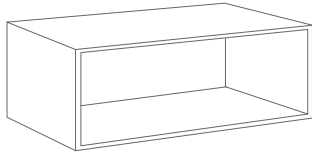

Open Storage Space
(No lining)

Your safe can be equipped with modules including drawers, watch winders. Hand crafted in Italy and covered with eco-leather. Available in 21 different colours.



Colour is a power which directly influences the soul

Module Outside Faux Leather

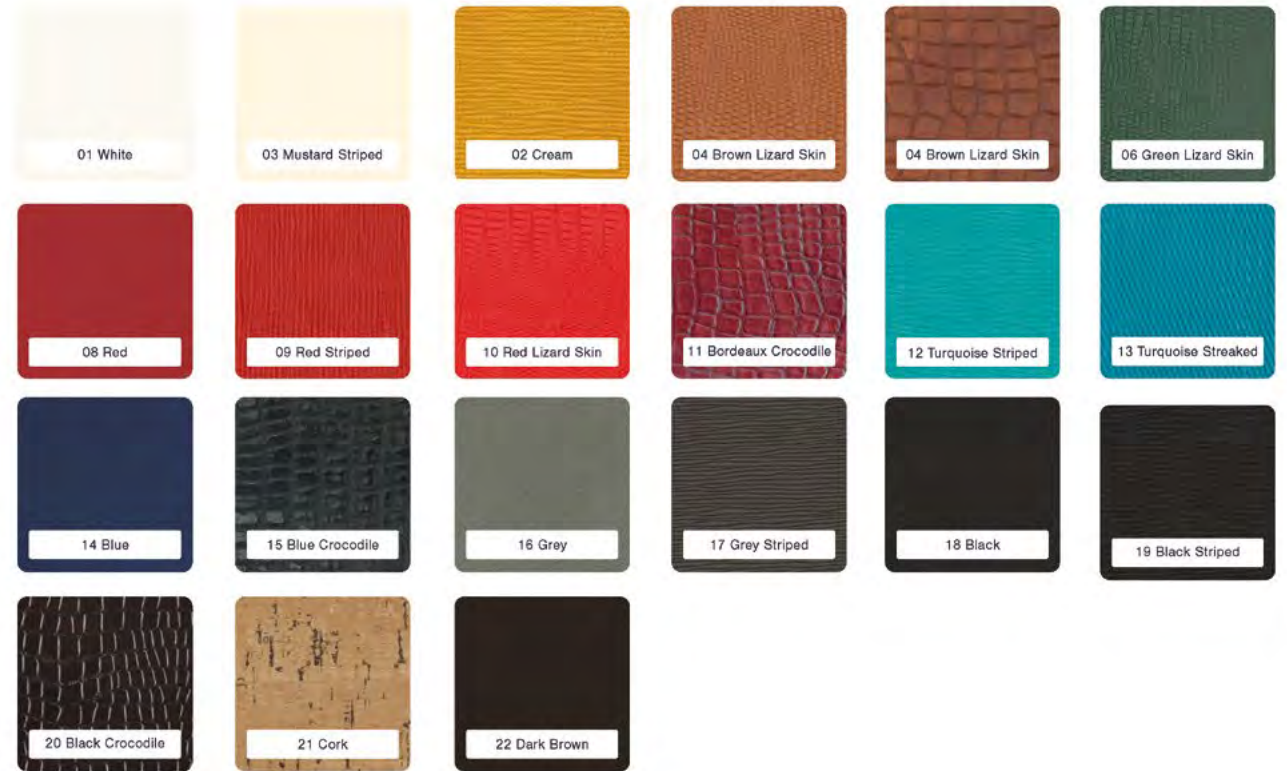

Drawer Velvet



Safe Colour



Choose your Jewellery Trays



Plain

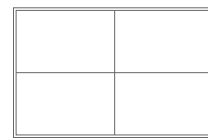

Four squares

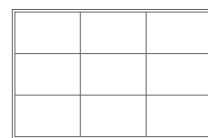

Nine squares

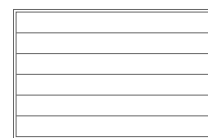

For necklaces

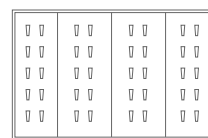

For rings

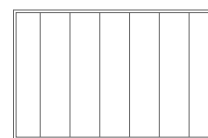

For watches

The drawers are internally covered with precious velvet. Customise with a choice of 17 colours.





Lusso Grade 2 available in 2 sizes

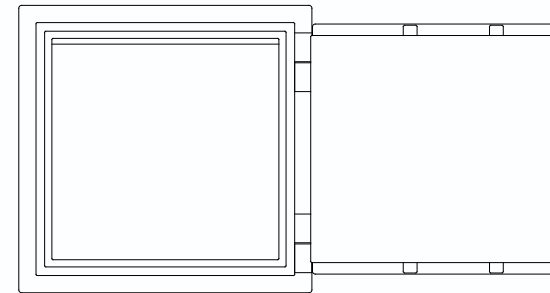

SIZE 1
External dimensions
 500 x 510 x 510
Internal dimensions
 385 x 395 x 360
Weight
 230 KG
2 Layouts

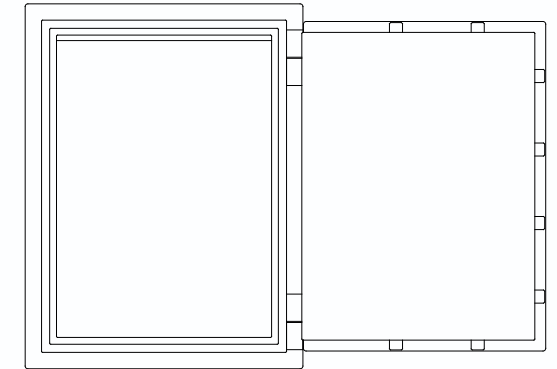

SIZE 2
External dimensions
 670 x 510 x 510
Internal dimensions
 555 x 395 x 360
Weight
 285 KG
3 Layouts

Lusso

GRADE 2

£17,500 Cash Rating
£175,000 Jewellery Rating
 Certified to EN1143-1
 Grade 2 by ECB•S.

AVAILABLE IN 2 SIZES

GRADE 3

£35,000 Cash Rating
£350,000 Jewellery Rating
 Certified to EN1143-1
 Grade 3 by ECB•S.

AVAILABLE IN 2 SIZES

Safe Colour

Choose your safe body finish
 from a choice of 4 colours.

Suede lining

The drawers are internally covered
 with precious velvet.
 Customise with a choice of 4 colours.

Wood Finish

The modules are externally
 covered with wood finish.
 Customise with a choice of 4 colours.

Choose your Jewellery Trays

4 Squares - Necklace - Plain - Ring rolls

Modules Safe Size 1

Open Space and 2 Drawers / 4 Drawers

Modules Safe Size 2

Open Space and 3 Drawers / 5 Drawers /
 2 Watch Winders and 3 Drawers

Electronic Lock

Lusso Grade 3 available in 2 sizes

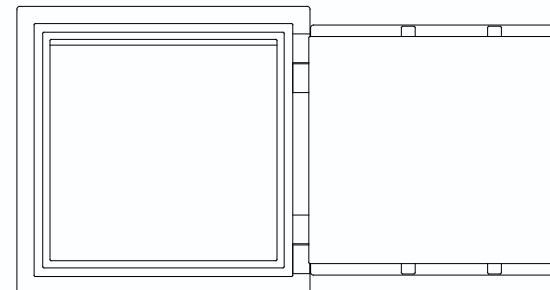

SIZE 1
External dimensions
 500 x 510 x 510
Internal dimensions
 385 x 395 x 360
Weight
 250 KG
2 Layouts

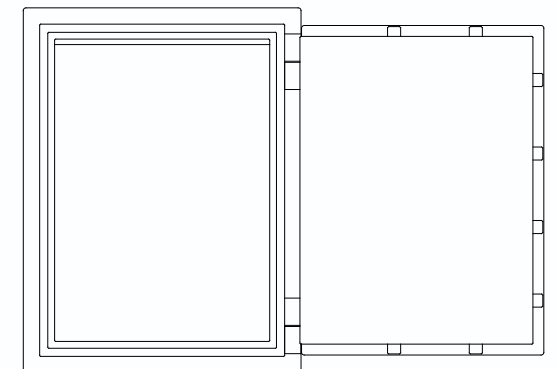

SIZE 2
External dimensions
 670 x 510 x 510
Internal dimensions
 555 x 395 x 360
Weight
 310 KG
3 Layouts

Interior Options

Layout option for size 1

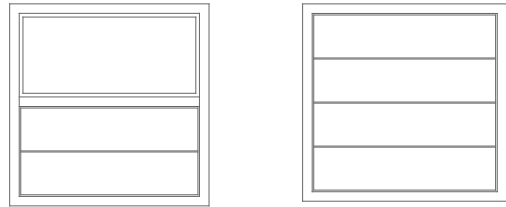

Open Space and 2 Drawers

4 Drawers

Layout option for size 2

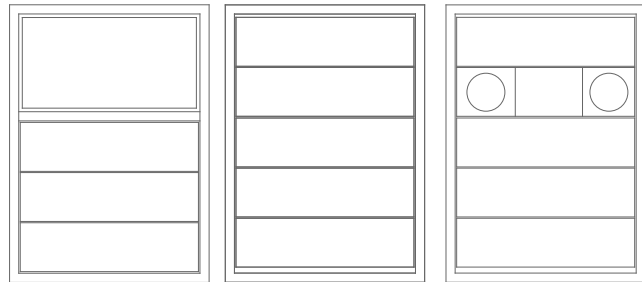

Open Space and 3 Drawers

5 Drawers

2 Watch Winders and 3 Drawers

The modules are externally covered with wood finish. Customise with a choice of 4 colours.



Suede Lining

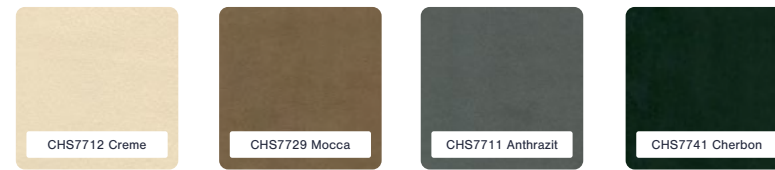

Wood Finish

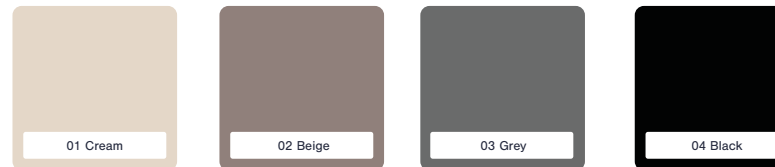

Safe Colour

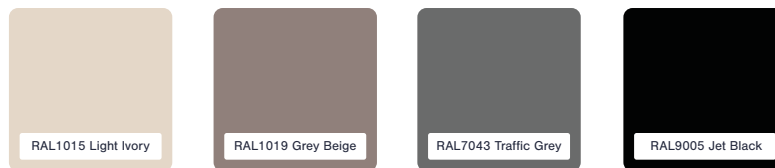

Lusso Design



Choose your Jewellery Trays

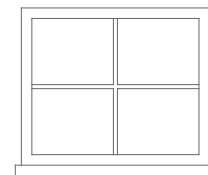

4 Squares

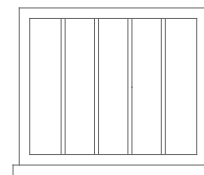

Necklace

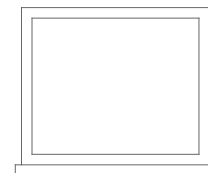

Plain

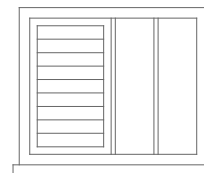

Ring rolls

The drawers are internally covered with precious velvet. Customise with a choice of 4 colours.

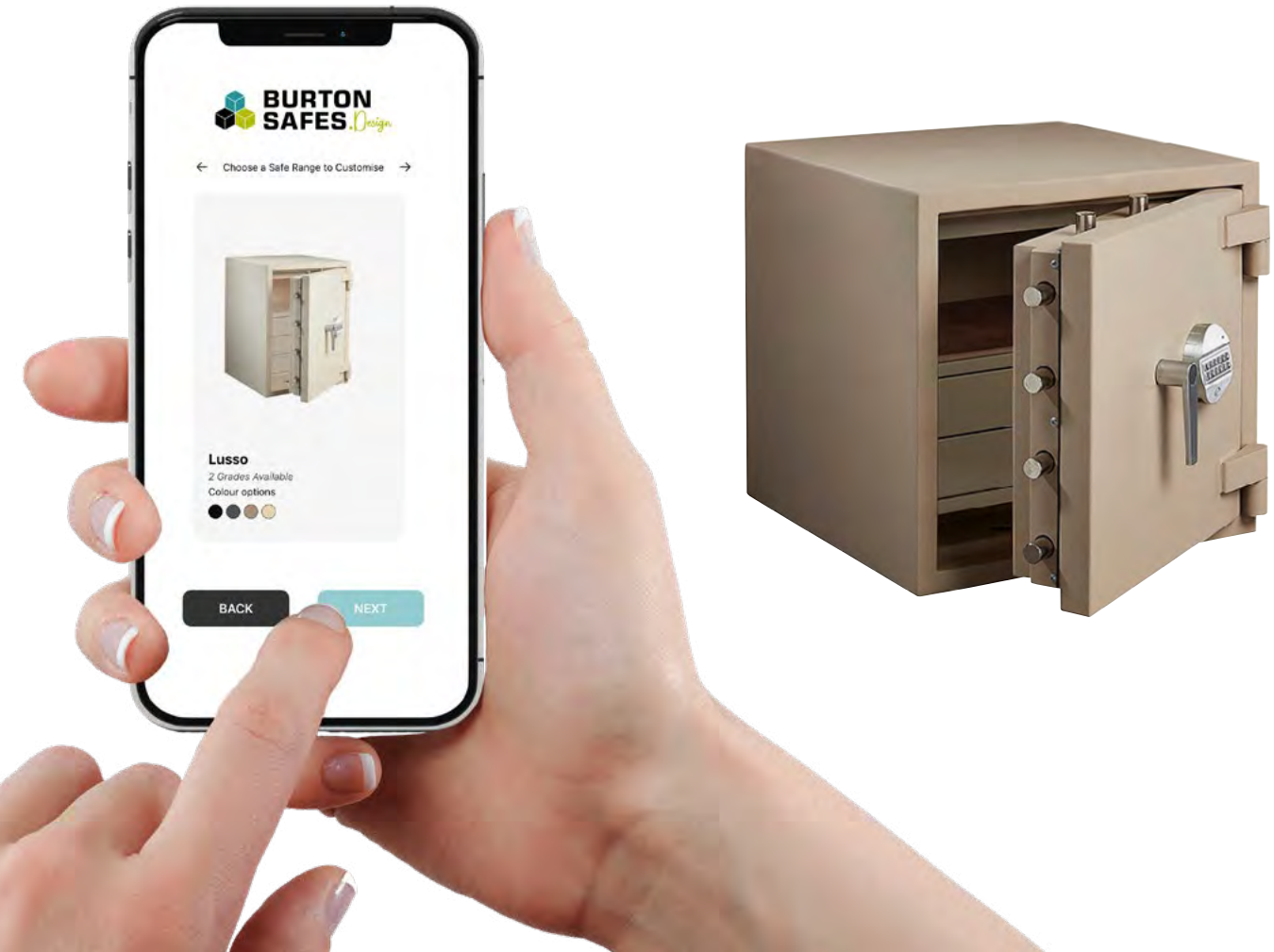



Our most Iconic Safes

GRADE 3

Certified to EN1143-1
Grade 3 by ECB • S.

£35,000 Cash Rating
£350,000 Jewellery Rating

GRADE 4

Certified to EN1143-1
Grade 4 by ECB • S.

£60,000 Cash Rating
£600,000 Jewellery Rating



Electronic Lock

AVAILABLE IN 5 SIZES

Safe Colour

10 colours available

Interior Finish

Customise with a
choice of 14 luxury finishes

Interior Modules

Watch winders - Power Panel
Low Drawer - High Drawer - Glass Shelf
USB Power - Space

Jewellery Trays

Jewellery tray - Open tray
(low and high trays)

Drawer Suede

Light Grey

Detailing

Silver Chrome or
Gold Chrome

Amario Lux Grade 3 Available in 5 different sizes

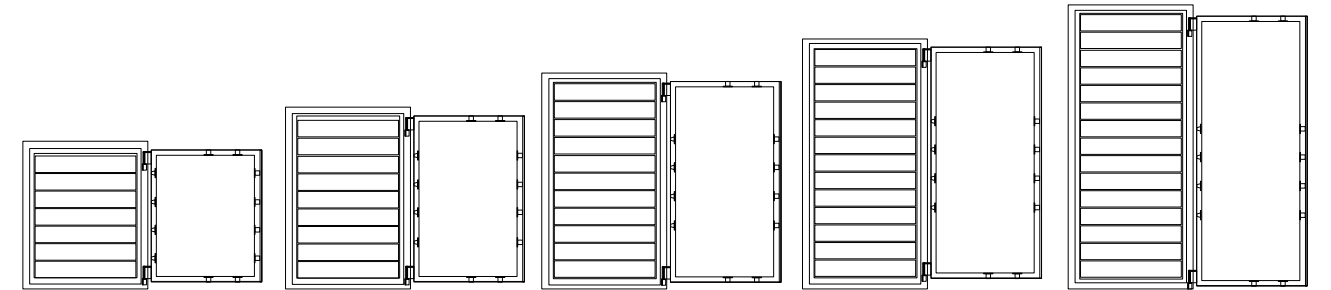

Size 3

Size 4

Size 5

Size 6

Size 7

External dimensions
650 x 550 x 550
Internal dimensions
550 x 450 x 395
Weight
340 KG

External dimensions
800 x 550 x 550
Internal dimensions
700 x 450 x 395
Weight
400 KG

External dimensions
950 x 550 x 550
Internal dimensions
850 x 450 x 395
Weight
460 KG

External dimensions
1100 x 550 x 550
Internal dimensions
1000 x 450 x 395
Weight
520 KG

External dimensions
1250 x 550 x 550
Internal dimensions
1150 x 450 x 395
Weight
580 KG

Amario Lux Grade 4 Available in 5 different sizes

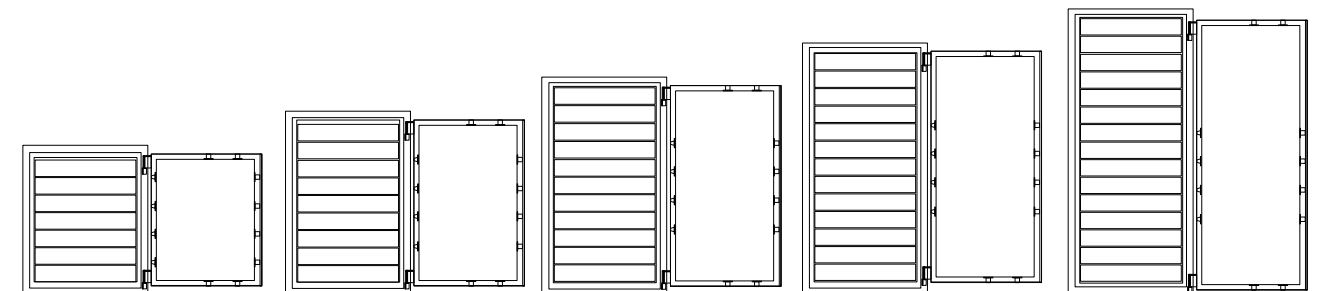

Size 3

Size 4

Size 5

Size 6

Size 7

External dimensions
650 x 550 x 550
Internal dimensions
550 x 450 x 395
Weight
350 KG

External dimensions
800 x 550 x 550
Internal dimensions
700 x 450 x 395
Weight
410 KG

External dimensions
950 x 550 x 550
Internal dimensions
850 x 450 x 395
Weight
475 KG

External dimensions
1100 x 550 x 550
Internal dimensions
1000 x 450 x 395
Weight
535 KG

External dimensions
1250 x 550 x 550
Internal dimensions
1150 x 450 x 395
Weight
600 KG

The perfect combination of quality,
functionality and security

Modules

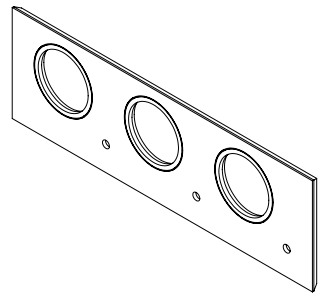

Watch winder

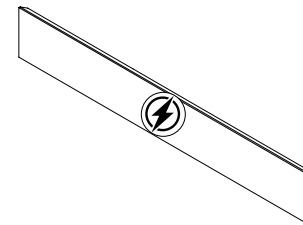

Power Panel

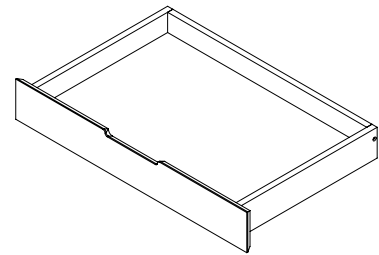

Low Drawer

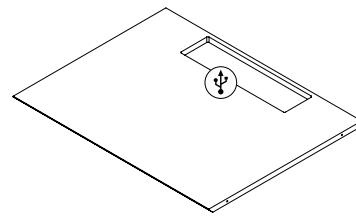

USB Power

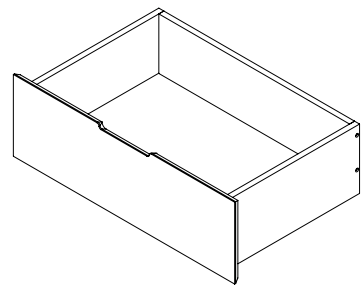

High Drawer

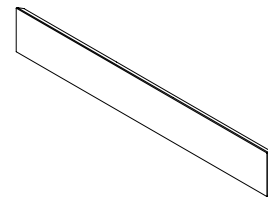

Space

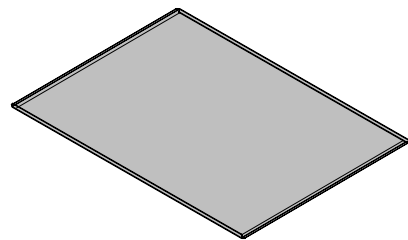

Glass Shelf



Available Jewellery Trays

High drawer

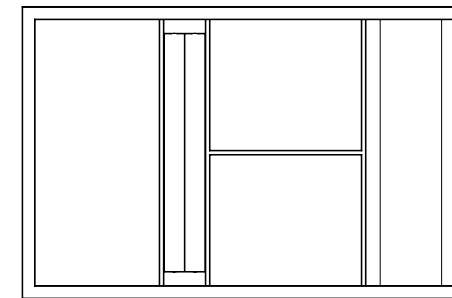

Jewellery tray

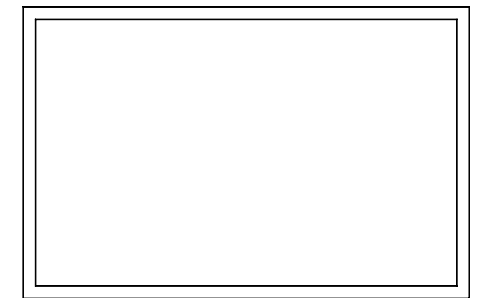

Open tray

Low drawer

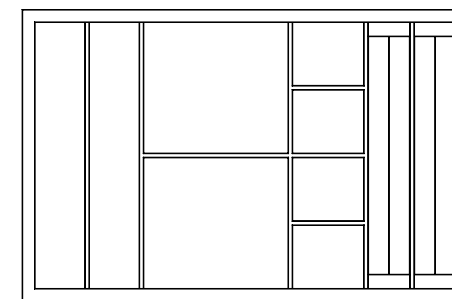

Jewellery tray

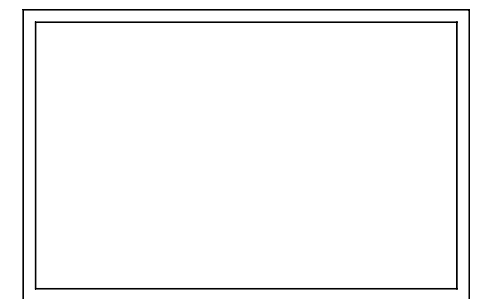

Open tray

The drawers are internally covered with a precious light grey Suede

Fully customizable from the inside to the outside

Customise each part your way!

DETAILED GOLD FINISH



Hinge Covers



Handle

Our safes are subject to various painting process stages, to obtain the high glossy finish

external finish.



Customise each part your way!

DETAILED SILVER FINISH



Locking Bolts



Lock

Drawer Suede



Light Grey

Interior Finish

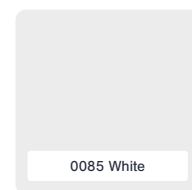

0085 White



0074 Pastel Grey



0077 Charcoal

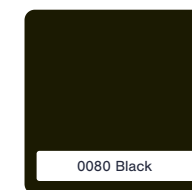

0080 Black

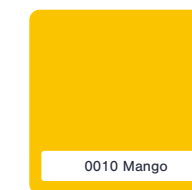

0010 Mango

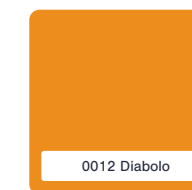

0012 Diabolo

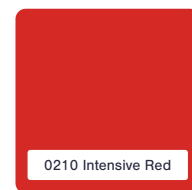

0210 Intensive Red



0024 Vivo

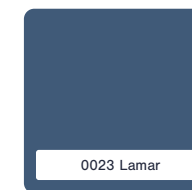

0023 Lamar

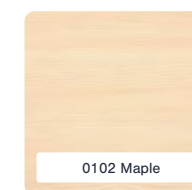

0102 Maple

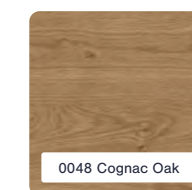

0048 Cognac Oak

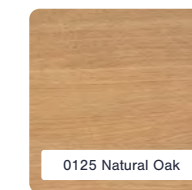

0125 Natural Oak

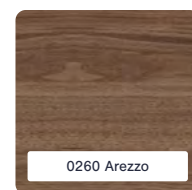

0260 Arezzo

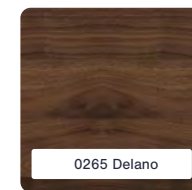

0265 Delano

Safe Colour

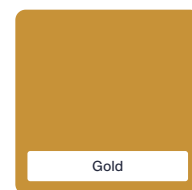

Gold



Silver Grey

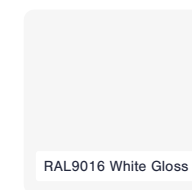

RAL9016 White Gloss

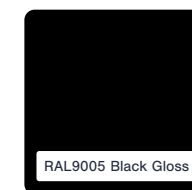

RAL9005 Black Gloss

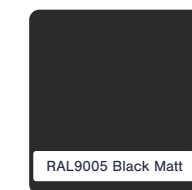

RAL9005 Black Matt



RAL1023 Traffic Yellow

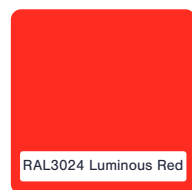

RAL3024 Luminous Red



RAL5002 Ultramarine Blue

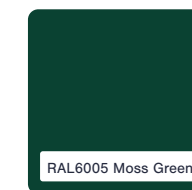

RAL6005 Moss Green



RAL3005 Wine Red

Detailing

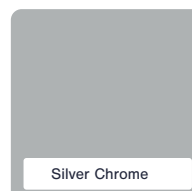

Silver Chrome

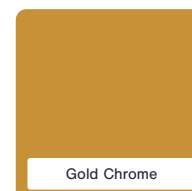

Gold Chrome

Krystal Display Safes



It's Krystal clear our range of display safes are designed for showing off and admiring your jewellery, antiques, watches, special gun collections, and other objects of beauty.

Careful attention to detail ensures a harmonious balance between beauty and security, all styled in a way that will enhance any room.

Each Krystal Display Safe is customisable with a choice of body paint finishes, internal colours, locking, handles and optional extras, making it easy to complement your existing décor.

Suitable for the storage of:

- Jewellery**
- Antiques**
- Watches**
- Gun collections**
- Ammunition**
- Objects of beauty**

Body: double-walled body, multi-walled body G1
Door: multi-walled door construction
Locking: 4-way locking bolt system - incl. overlapping profile on the hinge side

Standard option

Lock: high security key lock class I VdS with two keys (65 mm)
Boltwork handle: handle, protruding 35 mm
Hinges: internal
Door opening angle: 90°
Mounting holes: 1 holes in the floor and 2 on the backwall S2,
 2 holes in the floor and 2 on the backwall G0 / G1



Our Krystal range meets Police Preferred Standards for storing guns and firearms, is insurance approved for cash and valuables, and with its incredible glass display being resistant to bullets, axes, sledgehammers, grinders, drilling, and torch attacks offers the peace of mind you need to securely display all of your treasured items.

S2

KRYSTAL DISPLAY SAFE S2



A B

G0

KRYSTAL DISPLAY SAFE G0 - SIZE 1



A B E

G0

KRYSTAL DISPLAY SAFE G0 - SIZE 2



A B E

G1

KRYSTAL DISPLAY SAFE G1



A B E

Article

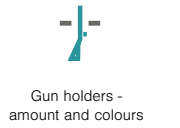
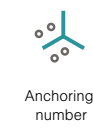
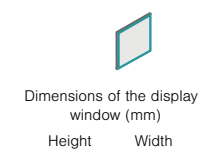
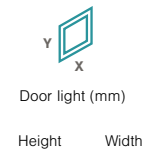
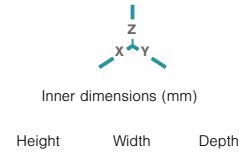
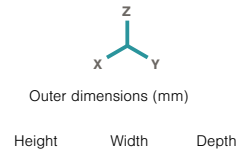
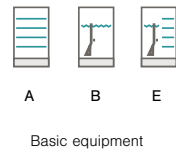

KRYSTAL DISPLAY SAFE S2

KRYSTAL DISPLAY SAFE S2 - SHELVES

A

1700 x 677 x 413

1647 x 594 x 322

1582 x 508

1182 x 395

181

1/2

2 4

-

KRYSTAL DISPLAY SAFE S2 - 10 GUNS

B

1700 x 677 x 413

1647 x 594 x 322

1582 x 508

1182 x 395

181

1/2

2 -

10 

KRYSTAL DISPLAY SAFE G0 - SIZE 1

KRYSTAL DISPLAY SAFE G0 - SHELVES SIZE 1

A

1802 x 840 x 450

1656 x 730 x 315

1632 x 645

1380 x 540

270

2/2

2 4+1

-

KRYSTAL DISPLAY SAFE G0 - 13 GUNS SIZE 1

B

1802 x 840 x 450

1656 x 730 x 315

1632 x 645

1380 x 540

270

2/2

2 4

13 

KRYSTAL DISPLAY SAFE G0 - 7 GUNS & SHELVES SIZE 1

E

1802 x 840 x 450

1656 x 730 x 315

1632 x 645

1380 x 540

270

2/2

2 4+1

7 

KRYSTAL DISPLAY SAFE G0 - SIZE 2

KRYSTAL DISPLAY SAFE G0 - SHELVES SIZE 2

A

1802 x 840 x 512

1656 x 730 x 378

1632 x 645

1380 x 540/340

313

2/2

2 1

-

KRYSTAL DISPLAY SAFE G0 - 13 GUNS SIZE 2

B

1802 x 840 x 512

1656 x 730 x 378

1632 x 645

1380 x 540/340

313

2/2

2 4+1

13 

KRYSTAL DISPLAY SAFE G0 - 7 GUNS & SHELVES SIZE 2

E

1802 x 840 x 512

1656 x 730 x 378

1632 x 645

1380 x 540/340

313

2/2

2 4+1

7 

KRYSTAL DISPLAY SAFE G1

KRYSTAL DISPLAY SAFE G1 - SHELVES

A

1802 x 840 x 500

1660 x 730 x 357

1623 x 637

1380 x 540

332

2/2

4+1

-

KRYSTAL DISPLAY SAFE G1 - 13 GUNS

B

1802 x 840 x 500

1660 x 730 x 357

1623 x 637

1380 x 540

332

2/2

1

13 

KRYSTAL DISPLAY SAFE G1 - 7 GUNS & SHELVES

E

1802 x 840 x 500

1660 x 730 x 357

1623 x 637

1380 x 540

332

2/2

4+1

7 

KRYSTAL DISPLAY SAFE S2 - OPTIONS

BASIC EQUIPMENT

A

TWO FIXED, METAL SHELVES

MOVABLE, GLASS SHELVES

B

GUN HOLDERS

TWO FIXED, METAL SHELVES

SUBLIMATION AND RAL COLOURS *

RAL 9010

RAL 9011

NUT

CHERRY WOOD

WALNUT

MAPLE

OAK WOOD

NEW
BODY COLOUR

RAL COLOURS

SALT LAKE 001

SALT LAKE 003

COLOURS OF THE INNER CARPET **

GREEN

RED

GREY

BEIGE

BLACK

LOCK OPTIONS

KEY LOCK

ELECTRONIC SUBLIMED

ELECTRONIC GOLD GLOSS

ELECTRONIC SILVER GLOSS

ELECTRONIC SILVER SATEEN

ELECTRONIC SALT LAKE 001

ELECTRONIC SALT LAKE 003

HANDLE OPTIONS

BRUSHED SILVER STEEL

SUBLIMED

GOLD SATEEN

SALT LAKE 001

SALT LAKE 003

GUN HOLDERS - COLOURS

WOOD-LIKE

RED

BEIGE

GREEN

BLACK

ADDITIONAL OPTIONS

LED LIGHT

INNER SAFE

KRYSTAL DISPLAY SAFE GO / G1 - OPTIONS

BASIC EQUIPMENT

A

GLASS SHELVES

B

GUN HOLDERS

E

GLASS SHELVES + GUN HOLDERS

REMARKS:

- * one fixed metal shelf at the bottom of the safe
- ** back wall not sublimated
- *** the carpet is located on the back wall, side walls and at the bottom

REMARKS CONCERNING THE SAFE ANCHORING TO THE BACK WALL:

The whole back wall is lined with the carpet - in order to anchor the safe to the wall, the carpet has to be notched or debonded



*The highest and most luxurious
level of security*

THE LUXURY RANGE

The Luxury Range from Burton Safes offers our clients the highest level of security, engineered to the most detailed level of precision. With over 30 years experience providing global security solutions, we have built a reputation around luxury, security, integrity and customer service.

Burton Safes is a leading supplier of luxurious security solutions, customised in Yorkshire, UK and delivered Worldwide. Our dedicated team of security experts work with our clients every step of the way, from design, planning and implementation.

We understand that each project is different which is why we build a security solution bespoke to each client. This could be a custom designed safe or even an internal security door, to aesthetically match other doors within the property.

Our Head Office and customising facility in Holmfirth, in the heart of Yorkshire, UK, is also the home of our Eurovault LX luxury safe. Our Eurovault LX offers a complete bespoke solution to create your perfect safe. Our team of expert craftsmen and women strive for perfection to create every unique Eurovault LX masterpiece.

The finest solid wood, hand crafted jewellery drawers finished in luxurious suede or leather offering the highest standards of British craftsmanship. Jewellery drawer layouts to suit all type of valuable possessions, including the option of integrated watch winder modules to show off the finest time pieces. Our expert team have designed and created bespoke luxury safes that have been delivered worldwide.



THE LUXURY RANGE
FROM BURTON SAFES

AS BESPOKE AS YOUR
INDIVIDUAL NEEDS



We offer a unique experience with over 30 safe sizes available. They are handcrafted in Yorkshire, UK. Our bespoke safes are finished to the highest standard. Our team of expert craftsmen and women provide luxurious, bespoke solutions. We can meet almost any requirement. Including handmade jewellery drawers and hand crafted upholstery. We use only the finest suede and leather.



We understand that each project is different. Which is why we build a security solution bespoke to each client. From matching colour swatches from your favourite car. To hand-stitching your family crest into the interior. We can ensure your safe is the only one of its kind in the world.

The Eurovault LX range is available in a variety of sizes with security grades ranging from EN1143-1 Grade 1 up to Grade 7. Other options in the range are glass fronted display cabinets and gun safes.

- Jewellery and valuables cover from £100,000 to £2,500,000
- Over 30 safe sizes available
- We can offer luxury security doors and panic rooms installed to meet you and your home's security needs
- Full design, consultancy and installation provided by the Burton Safes Luxury Team



When you place an order you will be assigned a project manager. They will oversee the process from design to build, to the final installation. With over 30 years experience of providing security solutions globally we have built a reputation of integrity and customer satisfaction and helped keep homes and families safe for decades.

AN EXCLUSIVE RANGE OF EXQUISITE SAFES USING THE FINEST MATERIALS. ALL HAND FINISHED USING THE BEST BRITISH CRAFTSMANSHIP TO GIVE THE SAFE YOUR PERSONAL TOUCH.



The Luxury Range | from Burton Safes

www.luxurysafe.co.uk | enquiries@burtonsecurity.com | +44 (0) 1484 663388



SAFE ROOMS | PANIC ROOMS SECURE ROOMS & VAULTS

AT HOME, AT WORK, AND IN LEISURE



EMBASSY MODULAR STEEL SECURITY WALLING

THE SURE DEFENCE

PROTECT YOUR FAMILY AND VALUED POSSESSIONS

WITH AN EMBASSY SAFE / PANIC ROOM.

With over 30 years' experience providing high security physical protection products, Burton Security can provide the best solutions to protect your family and most valuable possessions. Working with you allows us to design the highest level of bespoke safe rooms and vaults for your family to take lifesaving shelter during a robbery, burglary, home invasion or terrorist attack.

EMBASSY MODULAR STEEL SECURITY

Walling



A safe room, or panic room as they are often called, provides a safe hiding place for your loved ones until your security team or the emergency services can be contacted.

Coordinating directly with your interior designer and architect ensures that we identify the protection level required to create safe rooms that are attack resistant, bullet proof, functional, safe and aesthetically pleasing.

We have a choice of security rooms and walling levels to protect against physical attack tools and ballistic weapons, such as pistols, handguns, and rifles. Additionally, our range of luxury armoured and sliding doors can be hidden from view, something that can be specified during the design process.

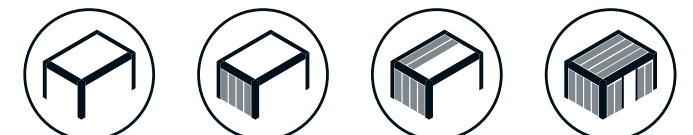
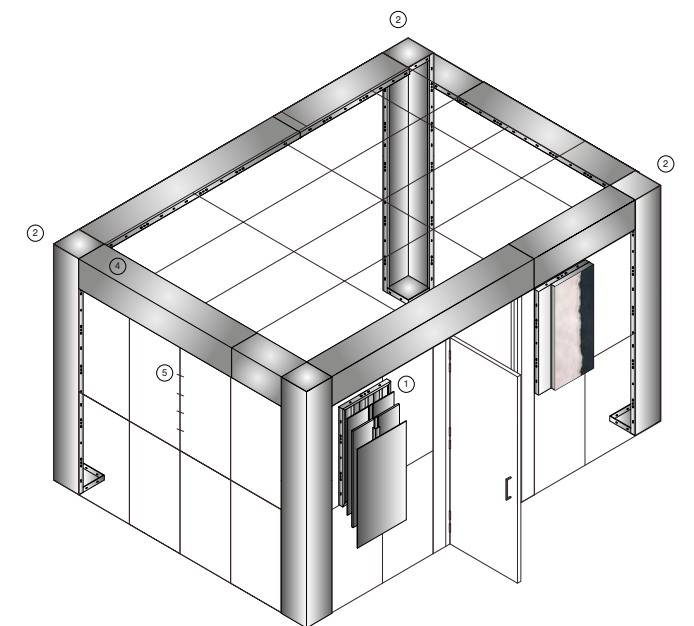

PRIVATE RESIDENCES, LUXURY APARTMENTS, YACHTS AND OFFICES



An Embassy safe / panic room or a vault can be built as a stand-alone room or we can discreetly convert existing areas of the home, such as bedrooms, walk in wardrobes, guest rooms, ensembles, living rooms, offices, and garages to keep your family and valuables safe from intruders.

Embassy panic rooms are ideal for high-net-worth individuals, dignitaries, and celebrities wanting to avoid life and death situations and protect the family in setting such as private residences, home offices, holiday homes, luxury apartments, and super yachts.

High Security Doors

Armoured security doors at the property boundaries can provide an additional layer of protection and time critical safety so you can reach your panic room in safety!

Our designs include adjoining rooms to create a central places of safety for the family with hidden armoured doors, manual or powered sliding doors, access control and window protection such as shutters, bar sets and bulletproof glass for the highest level of protection.

For larger ground floor installations designed to protect collections, art, classic cars, jewellery, precious metals, cash, and important documents we also have a range of strongrooms and vaults made from heavier steel and composite constructions.

Embassy Design

Enables architects and specifiers to embed secure design from the outset, creating the perfect balance of security and luxurious interior design.

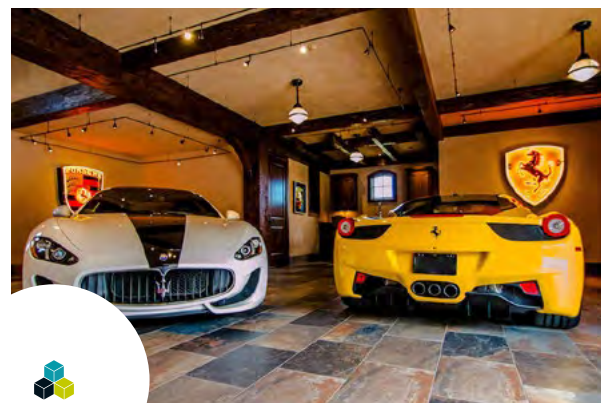

EMBASSIES, HOTELS AND SCHOOLS

In a world where the threat of terrorist attacks has become more common on Government embassies, hotels, retail areas, and sadly in schools too, the protection of personnel within safe areas of retreat has become more important to our way of living and is rightly now the everyday duty of care for many.

Our Embassy modular steel security walling is ideal for designing bespoke rooms or converting existing rooms to offer a high level of physical attack protection, ballistic resistant walling protection combined with bulletproof door sets creating the safe room required.

In these environments a well drilled emergency plan incorporating a designated, professionally designed safe room can save lives and help reduce the risk of robbery and hostage situations.

Working with your architects and designers each Embassy walling or safe room installation can be decorated discreetly to match its natural surroundings and create a hidden room or become part of a luxurious experience for clients, guests, visitors, pupils or staff.

Physical Security

Provides time delay. Delay equals safety and time to notify the Police authorities!



High Security Armoured Doors

We provide a large range of security door sets including traditionally hinged, luxury, and bespoke sliding door models!

Escape Rooms

An Embassy safe room is an ideal place of retreat and safety if under attack during a robbery, aggravated burglary or assault!

Embassy modular security steel walling and rooms installed for maximum protection worldwide.

ARTS & LEISURE

It has been estimated by U.S. News that more than 50,000 pieces of artwork are stolen globally each year, and that 40% of these crimes are committed in the UK. In addition to the billions of pounds worth of loss attributed to these thefts, storage vault fires have accounted for many millions more. The risk to art, film and musical history has almost never been greater as general concerns surrounding worldwide security matters continue to grow, and as the threats from terrorism and armed robbery also remain high.

Our bespoke Embassy modular steel security walling, strongrooms, portable security rooms and vault systems are ideal for designing both fixed and temporary solutions to these threats. Suitable too for the conversion of existing rooms within buildings, vehicles, and yachts, Embassy offers a high level of physical attack protection, fire protection and ballistic resistance.

Whatever your requirements, choose Embassy security rooms and doors to create the ultimate protection against burglary, robbery, fire and armed assault.



Jewels and Precious Metals

- Regalia
- Crowns
- Rings
- Diamonds, Sapphires, Emeralds, Rubies, Pearls,
- Opel's
- Gold, Silver, Platinum and Palladium
- Collections
- Watches

The Seven Seas

- Luxury Yachts
- Superyachts
- Boats
- Ships
- Marinas
- Maritime

Art & Literature

- Museums
- Galleries
- Art
- History
- Science
- Plant, animal, fossil, rock and mineral
- Architectural
- Design, fashion and textiles
- Libraries
- Maritime
- Transport
- Modern Art
- Auction Houses
- Religious Artifacts
- Exhibitions
- Private Collections
- Vaults

Music & Film

- Music Studios
- Master Recordings
- Multitrack Tapes
- Sound Laboratories
- Memorabilia
- Film Reels
- Music and Film Collections
- Instrument and History
- Collectors

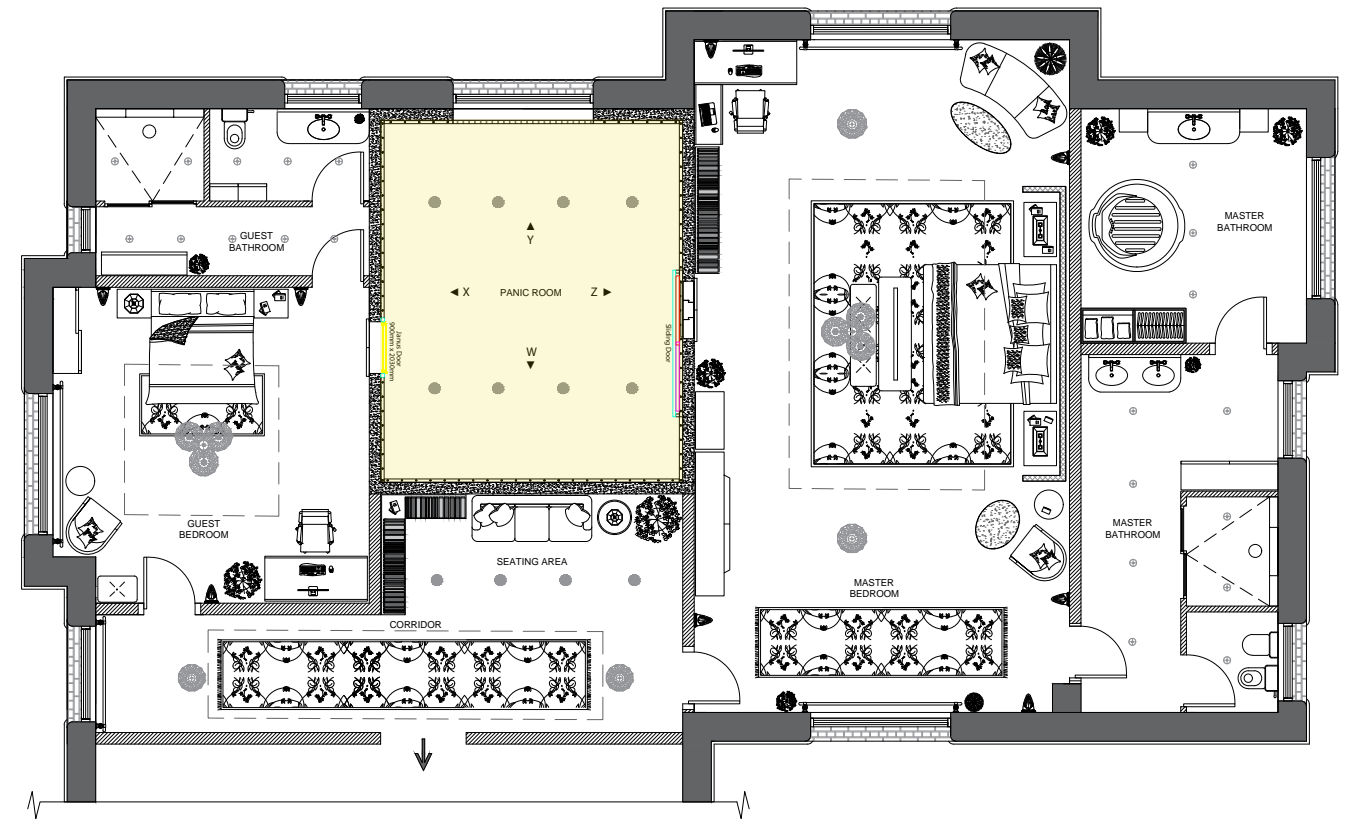
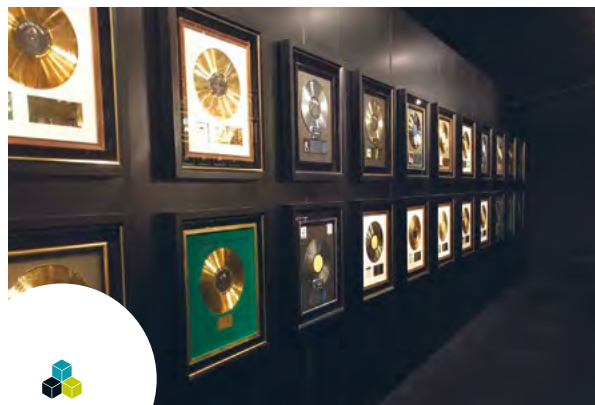

ARCHITECTS, DESIGNERS & CONSTRUCTION

Embassy modular steel security walling and our high security luxurious safes are ideal for designing bespoke rooms or converting existing rooms, offering a high level of physical attack protection, ballistic resistant walling protection combined with bulletproof door sets creating the safe room required.

part of our fully comprehensive consultation. Offering our customers not only unique, bespoke safe and panic rooms but a complete range of products for your home and business that will protect your most valuable possessions.

We carefully listen to our clients so we can fully understand their security needs, concerns and lifestyle. With a collaborative approach with our clients, their designers and architects we work to exceed expectations in all that we deliver with that personal touch which makes us unique in our approach.

Working with your professionals drawn from architecture, interior design, construction and project management fields we can provide an exclusive range of exquisite safes using the finest materials. All hand finished using the best British craftsmanship to give the safe your personal touch.

Following on from your preliminary discussion to assess your security needs, now your attention can turn to the finer details to ensure your chosen safe room compliments your lifestyle. Working with your designers we can combine innovative high security solutions with architecture and interior design to create wonderful living spaces to fit in with your lifestyle, bringing everything together to create a beautiful home.

Embassy is manufactured in the United Kingdom through design, innovation and investment in British engineering. We look forward to discussing your luxury bespoke requirements with our professional team as

Ultimate Privacy

We offer peace of mind that your security project will be discreetly designed, managed and installed by our expert UK team.

Our team will ensure that everything is taken care of, from design to install we give you complete transparency and privacy.

Trusted

Product quality, trust, honesty, reliability and professionalism provided as standard throughout the whole journey

Expertise

We have a wealth of expertise in-house that sets our services apart in the world of personal and valuables protection in a luxury setting



RETAIL AND COMMERCIAL



From the world's most advanced safe deposit centres in Hong Kong, to securing cash, bullion and valuables in banks and retailers across Europe and the Middle East; the team at Burton Security have the experience to advise, design, and deliver physical security solutions to protect you, your staff and your assets.

Embassy modular steel security walling, vaults and high security doors are ideal for designing bespoke rooms or converting existing rooms to offer a high level of physical attack protection, ballistic resistance, and controlled access or fire escape.

Our security solutions and safes can be found in most high street stores, superstores, banks, safe deposit centres, and protecting high street ATM's.

Unfortunately, the current cost of living crisis has seen a huge increase in theft from supermarkets. Working with heads of security we have designed anti-theft solutions to protect the stored cash within self-checkout machines, safely prevent snatch theft shoplifting via fire escapes, supply trolleys to aid the safe transit of cash through busy stores, and the ever-important service and daily management of all types of onsite security assets.

With a burgeoning reputation for providing turnkey solutions Burton Security are the perfect partner for anyone considering investing in the security of safe deposit centres, sanctuary rooms for high-net-worth individuals, cash handling areas, retail stores, bookmakers, banks, and home security too.

Jewellers & High Street Stores

An Embassy safe room is an ideal place of retreat and safety if under attack during an aggravated burglary!



ARMORIES, FIRING RANGES & GUN COLLECTIONS

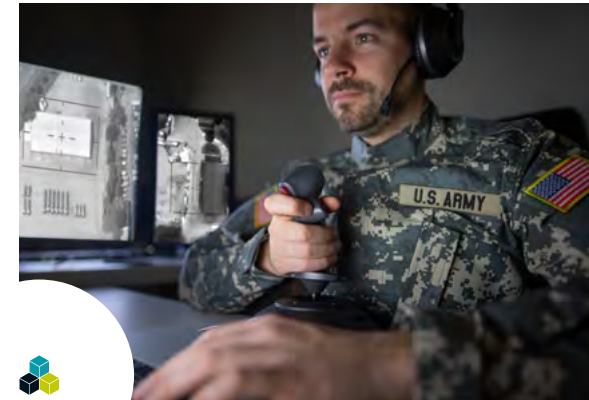

MILITARY

- Armouries
- Shooting Ranges
- Gun Clubs
- Gun Collections
- Antiques

BALLISTIC RATINGS

Tested and certified Bullet-resistant performance features FB1 – FB7 can be combined with burglary resistance performance levels 1 – 8.

TECH TALK

1001.01 is a technical document that specifies the performance requirements that equipment should meet to satisfy the needs of certification and procurement bodies as well as the individual user.

We have a large range of bespoke and off the shelf solutions developed for storing guns, protecting personnel in armouries, at shooting ranges, and which provide physical security protection when threatened with a firearm.

Our modular layered approach to designing and manufacturing Embassy walling means we can apply levels of materials that are fully tested and certified to BR1 to BR7, EN1522 FSG, and EN1523 FSG standards for ballistic resistant protection.

Personnel protection for the inside of gun rooms, safe room or areas used for firing weapons can be lined with our coatings developed and fully tested at Precision Ballistics Laboratories to test procedure 1001.01 for Anti-Spall and Anti-Ricochet properties.

Embassy modular steel security walling is ideal for designing a layered approach for building secure rooms and portable rooms that can include physical security, ballistic protection and anti-ricochet protection.



For smaller or additional secure gun storage and gun collection displays we have a full range of Sold Secure tested, police preferred gun safes and high security luxury glass display safes.



Armouries

Armouries Shooting Ranges Gun Clubs

Embassy Code	Security Walling Details	Security Level	Certified Security	Certified Ballistic	Attack Threat Protection	Panel Thickness mm	Weight p/m2	
E1	Single layer steel fabrication wall panel	1	*	-	Low technology level of attack using small, very easily concealed tools.	50mm	22 kg	
E2	Single layer steel fabrication wall panel with additional steel bracing	2	*	-	More determined attack using easily concealed tools of a greater mechanical advantage.	50mm	26 kg	
E3	Single layer steel fabrication wall panel with higher level additional steel bracing	3	*	-	Deliberate forced entry using a wide selection of commonly available, relatively easily concealed tools.	50mm	51 kg	
E4	Multi layered steel fabrication wall panel with higher level additional steel bracing	4	*	-	Experienced attempts at forced entry and threat to life.	50mm	80 kg	
E4 EB4	Multi layered steel fabrication wall panel with higher level additional steel bracing and ultra hardened ballistic steel	4 + 4B	*	FB4	Experienced attempts at forced entry and threat to life, including the use of ballistic weapons.	53mm	82 kg	
E5	Heavy duty multi layered steel fabrication wall panel with higher level additional steel bracing	5	*	-	Experienced attempts at forced entry using tools of a greater battery power.	54mm	88 kg	
E6	Heavier duty multi layered steel and composite panel fabrication wall panel with higher level hardened additional steel bracing	6	*	-	Professional attempts at forced entry into higher value storage areas and threat to life.	54mm	100 kg	
E6 EB6	Heavier duty multi layered steel and composite panel fabrication wall panel with higher level hardened additional steel bracing and ultra hardened thicker ballistic steel	6 + 6B	*	FB6	Professional attempts at forced entry into higher value storage areas and threat to life, including the use of ballistic weapons.	56mm	121 kg	
O6	High security strongroom modular walling manufactured of steel construction with anti-cut brace bars and a re-enforced concrete composite suitable for heavy duty vault doors. Certified by LPCB and ECB.S	**	6V	LPS1175 F10 (SR6) and G5 EN1143-1Grade 2	-	Professional attempts at forced entry into higher value storage areas and threat to life.	27mm	90 kg
C7	Higher level of thicker vault walling manufactured of heavy steel construction with anti-cut brace bars, barrier materials and dense re-enforced concrete composite suitable for heavy duty vault doors	***	7	EN1143-1Grade 4	-	Enhanced professional attempts of access to high value assets.	70mm	210 kg
C8	Higher level of thicker vault walling including EX protection against explosives, manufactured of heavy steel construction with anti-cut brace bars, barrier materials and dense re-enforced concrete composite suitable for heavy duty vault doors. Certified by ECB.S	***	8	EN1143-1Grade 6	-	Extreme methods of access to very high value assets using portable tools.	70mm	225 kg
Optional Wall Linings								
EB4	Advanced hardened steel protection plates with guaranteed ballistic properties	4B	-	FB4	Attckers with Rifles, automatic pistols and hand guns	3mm	25 kg	
EB6	Advanced hardened steel protection plates with higher levels of guaranteed ballistic properties	6B	-	FB6	Attackers Rifles, automatic pistols, hand guns, assault rifles and rifles FMJ (full metal jacket)	6mm	52 kg	
EAR	Anti-Ricochet and anti-Spall Ballistic lining and panelling	AR	-	PBL1001.01	Attackers and misfiring of weapons -Tested in accordance with PBL1001.0 Standard test method against the following threats 62g Fed Tac Bon, 5.56x45mm SS109, 9mm 124grn TMJ, .38s&pc 158grn JSP and 7.62 150grn Steel FMJ	30mm	4.5 kg	
RWA45	Rockwool high quality, high density resin bonded slabs	Insulation	EN 13162 Euroclass A1	-	Thermal, acoustic and fire resistant insulation	25-100mm	1 kg	

* Non certified

**Manufactured in the EU and certified in the UK to LPS 1175 Issue 8 F10 SR6 and G5 by LPCB - Built to a Police Preferred Specification - Secured By Design



***Manufactured in the EU and certified to EN1143-1 G4 and EN1143-1 G6 by ECB.S - Built to a Police Preferred Specification - Secured By Design



EXAMPLE EMBASSY MODULAR ROOM

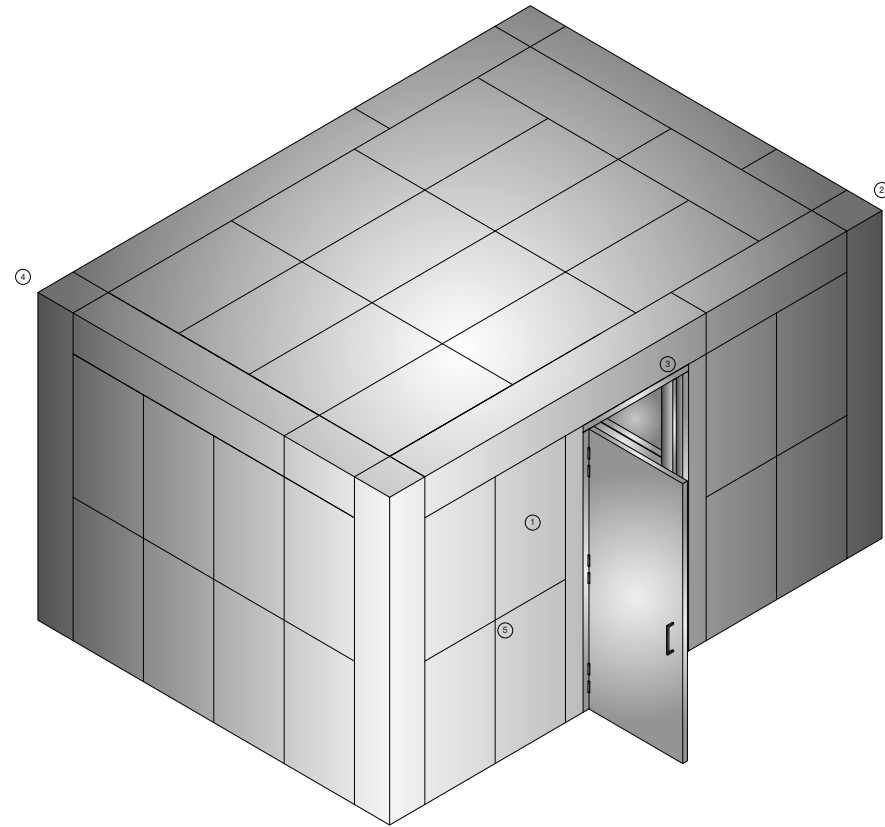

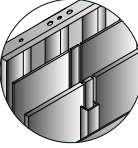
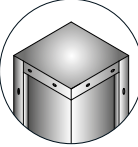
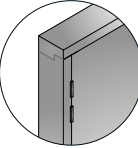
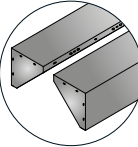
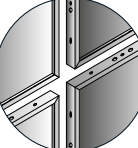
- ① Panel Section 
- ② Corner Panel 
- ③ Door Frame 
- ④ Top Edge Panel 
- ⑤ Modular Fixing 

EXAMPLE EMBASSY MODULAR WALLING AND DOORS

Layered construction providing maximum security

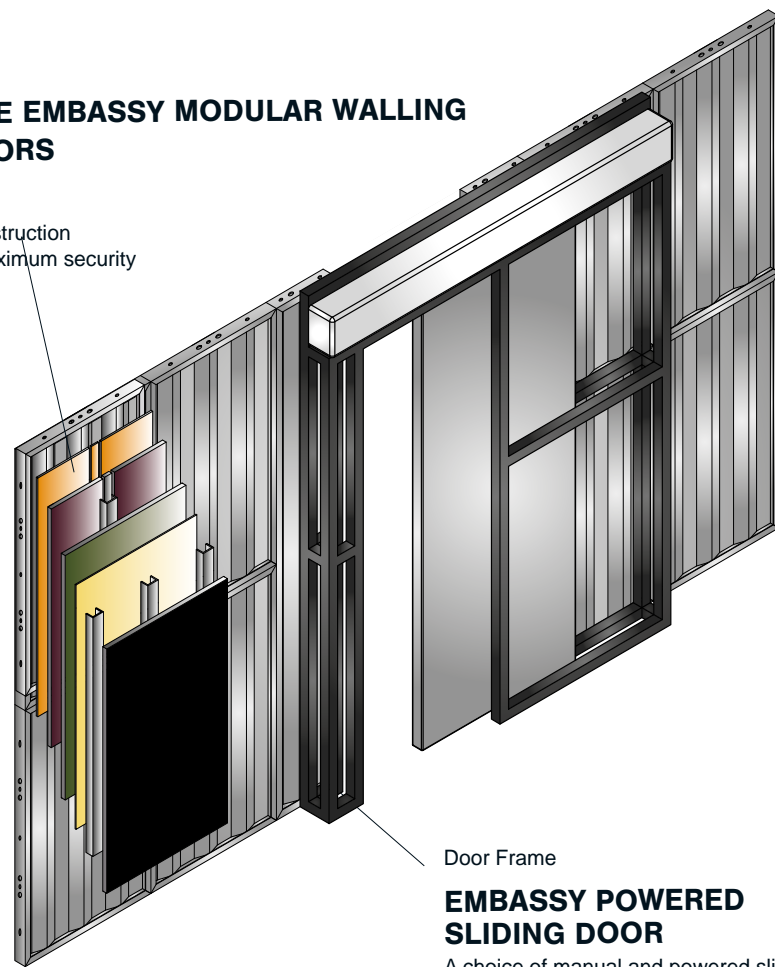

Door Frame

EMBASSY POWERED SLIDING DOOR

A choice of manual and powered sliding doors protected by Embassy walling



EMBASSY DOOR SET

Normally hinged bespoke security door set

EMBASSY MODULAR STEEL SECURITY WALLING



E1



E2

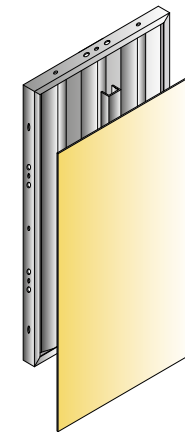

E4 EB4

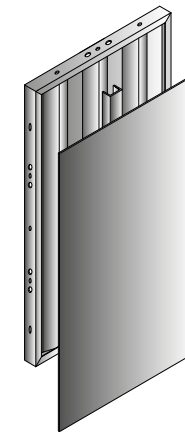

E5

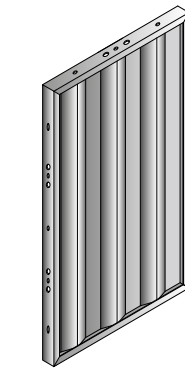

E3

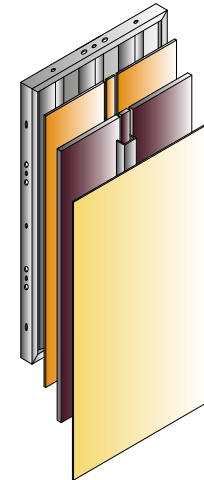

E6

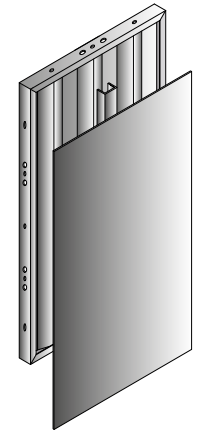

E4

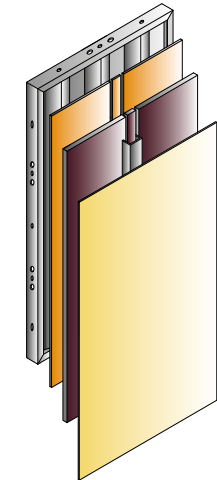

E6 EB6

Optional Modular Security Panels



EB4

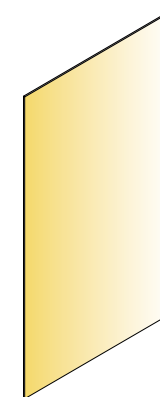

EB6



EAR

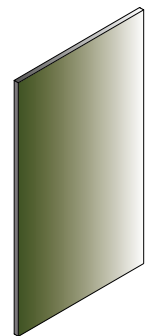

RWA45

OUR PRODUCT RANGE

Modular Security Panel levels

SECTORS WE SERVE



PR EMBASSY

- Critical National infrastructure
- Data Centres
- Nuclear & Utilities
- Petrochemical
-
- Retail
- Warehousing
- Kiosk
-
- Utilities
- Gas
- Electricity
- Water
- Renewables
- Battery Energy Storage System
- Power
- Hazardous Waste
-
- Transport
- Marine
- Airports
- Rail
-
- Healthcare
- Medical
- Laboratories
- Pharmaceuticals
- Secure Storage
-
- High Security
- ATM
- Banking
- Cash Handling
- Safe Deposit Centres
- Prisons
- Residential
- Police
- Armouries
- Military
- Gun Storage
-
- Education
- Schools
- Communal
-
- Architecture
- Construction
-
- Arts and Museums



Burton Security's core principle is to ensure products are tested to the highest standards. We are proud to have tested products to LPCB standards and feature in Red Book Live.

DESIGN & INNOVATION THE SURE DEFENCE TEAM

We are proud to manufacture our Embassy modular steel security walling and safe room products here in the UK. Our growth is through design, innovation and investment in British engineering.

Each project is managed and designed in house meaning we can offer a full turnkey security solution starting with a dedicated security team of experts who will discuss your requirements and start putting your concept plans into a working design.

Our design team will then create CAD drawings to match your space and the security protection level required, followed with a quotation which will be prepared for you to review.

Once the security design project has been agreed you will be introduced to a dedicated project manager who will oversee the whole production and installation process, starting with the all-important on-site survey.

Your bespoke Embassy walling or room will then go into production at our own fabrication workshops, ready for our skilled and fully vetted safe & vault installation engineers to install on site.



ATM Rooms and Banking



Safe Deposit Centres
Cash Handling



Critical National infrastructure
Nuclear



Pharmaceutical
Laboratories
Healthcare

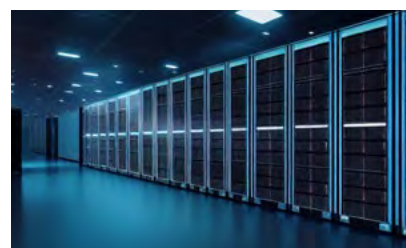

Data Centres

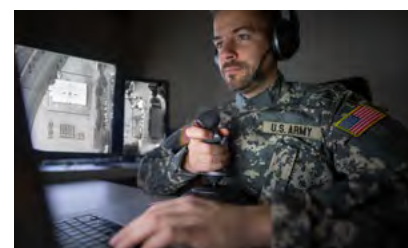

Military
Gun Storage

Police Preferred Specification

Proud to feature 100's of Secured by Design (SBD) official police security products that work to improve the security of buildings and their immediate surroundings to provide safe places to live, work, shop and visit.

Burton Security - On Every Street

We have served the Banking, ATM, Safe Deposit, Vault and Large Retail Stores for over 30 Years!

Award-winning Security Team

We have won numerous security industry award for fire and physical security designs.



ORTHRUS Strongrooms

LPS1175: Issue 8 F10 (SR6) and G5 Certified Room

Protecting People And Valuables



LPS1175: Issue 8
Cert No: 1000 k

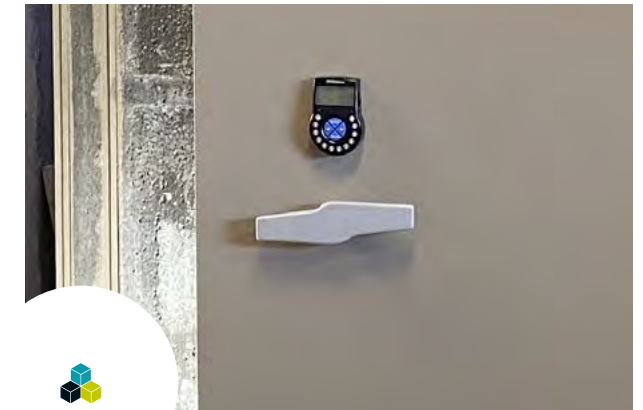

A free-standing high security solution of modular construction, Orthrus delivers optimum price/performance ratio. It is certified to the very latest LPS standard – LPS1175: Issue 8 and has achieved security rating F10 (SR6) G5. Each room is built to order according to the individual size and security requirements of the client. The flexibility of design and build allow this to be the perfect solution in the commercial world for high value items or indeed military/government use for sensitive materials or meeting spaces.

- Free-standing high security safe room
- Modular construction to create bespoke rooms built to your specification
- Orthrus rooms Independently tested and certified to LPS1175 (Issue 8) F10 (SR6) G5
- Built to a Police Preferred Specification -Secured by Design
- Ideal solution for creating a secure space within an existing structure
- Ideal for commercial, military and government use
- Exceeds requirements of the UK Environment Agency for the storage of radioactive source material/equipment
- Panel widths range from 150mm to 1500mm
- Rooms can be 5 or 6 sided
- Design, consultancy service and installation provided by Burton Safes
- The door and locking system can be connected to client's own alarm system and access control system
- A 2nd or 3rd lock can be added to your vault door if required
- Lock features 4 manager codes, 36 user codes, time delay and time windows, dual user functions and audit trails
- Optional emergency door, access hatch, pass through door is available

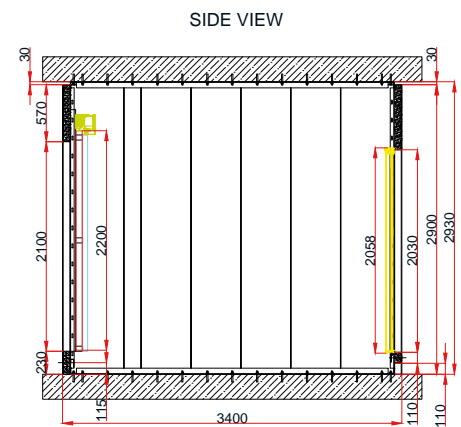

Locking Options



Dual Locking



Pin



Dial

FRONT VIEW

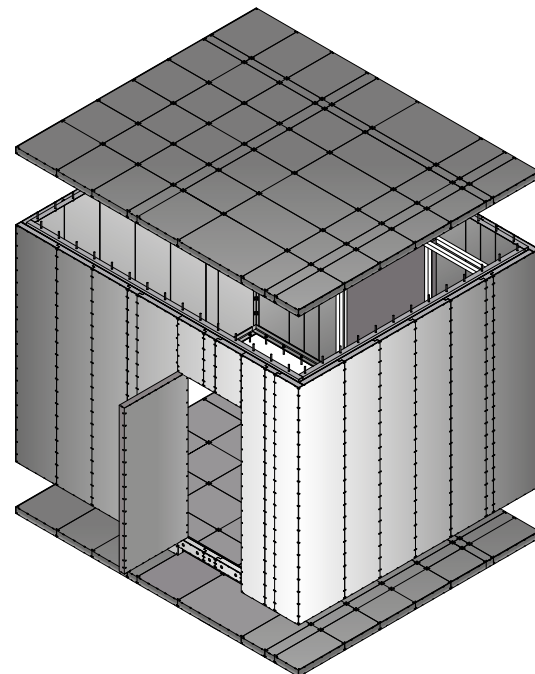
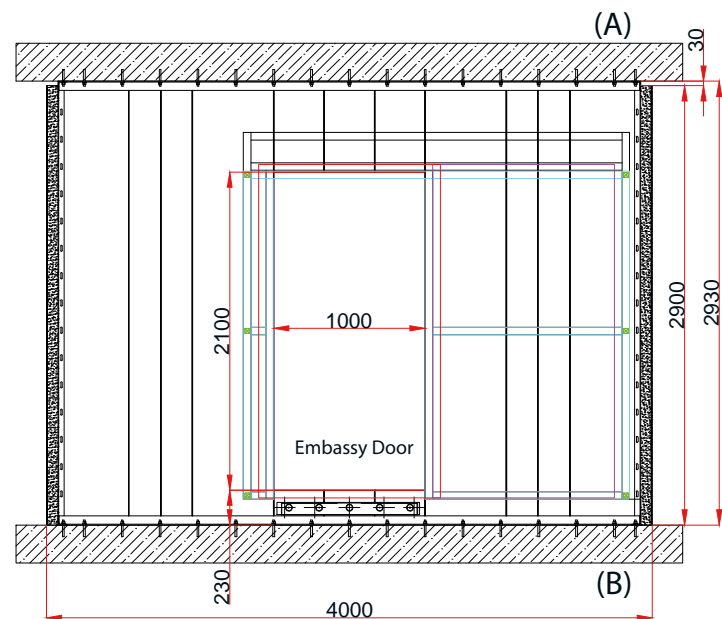

Vault panel information

Model	Min-Max Length*	Min-Max Width	Thickness	Weight p/m2
Orthrus	1950 - 3950 (wall) 2900 (ceiling)	150 - 1500	27	105kg

Vault door information

Model	Clear Opening Height	Clear Opening Width	Thickness	Weight p/m2
Standard Size	1960	910	160	900
Certified Range	1810 - 3950	510 - 1950	160	900
Emergency Door (in wall panels)	510	1068	160	450

*without additional steel supports

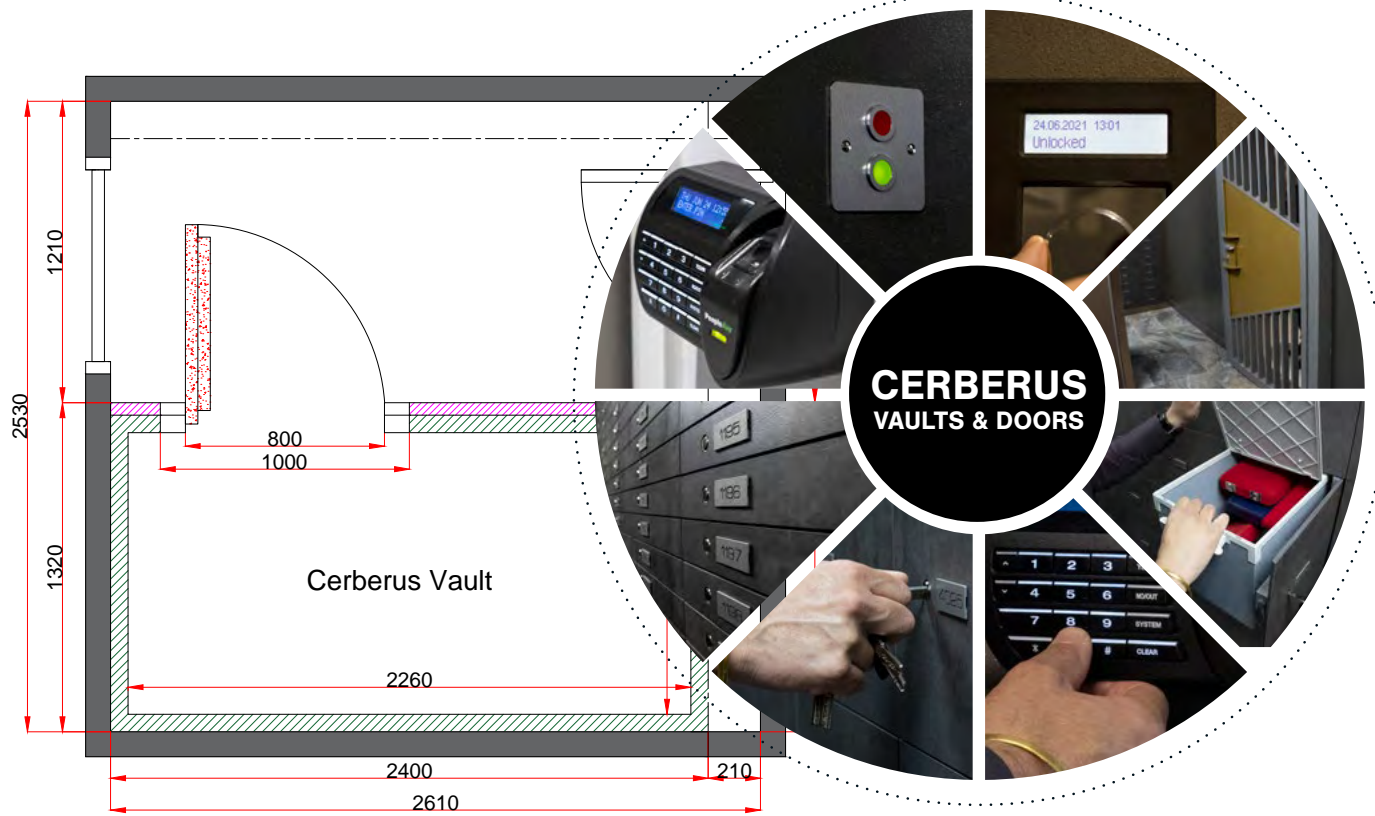

BANKING • SAFE DEPOSIT • CASH CENTRES • SECURE STORAGE



Our Vaults are unrivalled in its success, due to the modular nature of its design, and the scalable levels of security.

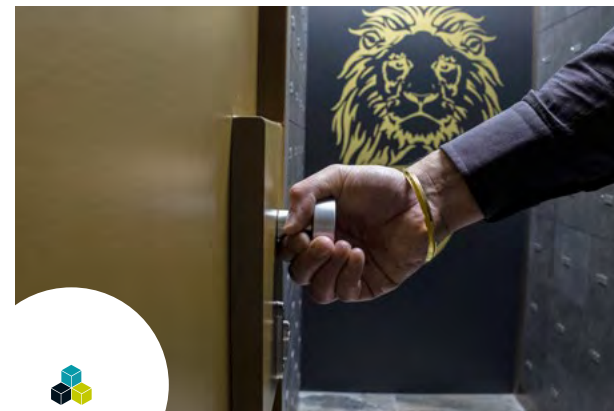

- Independently tested and certified to EN1143-1 Grades 1 - 13
- Grades 6 - 13 have been tested and certified to EX, providing additional protection against explosives
- Grades 8 - 13 have been tested and certified to CD, providing special protection against core drills
- Insurance approved by the AiS
- Built to a Police Preferred Specification - Secured by Design
- Designed to suit your size and security requirements
- Panels can be provided in lengths of up to 3600mm and can be fitted with cable and ventilation holes if required
- Mounting plates for seismic detectors can be added to your vault
- Steel cladding for the exterior is available on request
- Burton Safes offer a full consultation, design and building service. Upon completion the room is inspected and registered with VDS
- All Cerberus doors come with 2 locks as standard and a third can be ordered on request. The locks are located on the outside only

- Cerberus doors can be supplied with key, mechanical combination or electronic locks
- Electronic locks can offer redundant systems, dual user, time delay, time lock, duress alarms, audit trails, one time codes, remote programming and tiered access rights
- All doors can only open outwards and can open 180°
- An emergency door can be integrated into the main vault door or installed as a separate door*
- A day gate can be fitted to the main vault door on request and comes with a single key lock and a second key or electric strike
- Exit handles and hydraulic closers can be added on request

Locking Options

*Integrated door in door only available on Grades 1-3



Vault Model	Grade (EN1143-1)	Wall Thickness	Weight p/m2	Standard Door Aperture	Weight of Standard Door
Cerberus 1	1	27	100kg	1960 x 910	790kg
Cerberus 2 / Orthrus	2	27	105kg	1960 x 910	795kg
Cerberus 3	3	70	210kg	1960 x 910	823kg
Cerberus 4	4	70	210kg	1960 x 910	900kg
Cerberus 5	5	70	210kg	1960 x 910	900kg
Cerberus 6	6	70	225kg	1960 x 910	900kg
Cerberus 8	8	125	390kg	1960 x 910	1410kg
Cerberus 10	10	195	600kg	1960 x 910	2000kg
Cerberus 12	12	250	900kg	1960 x 910	2805kg
Cerberus 13	13	415	1215kg	1960 x 920	4300kg

TRANSPORTA Strongrooms



Model	External (HxWxD)	Internal (HxWxD)	Weight	Cash Rating
SC10	2440 x 2440 x 2980	2110 x 2110 x 2560	2040kg	£4,000
SC20	2440 x 2440 x 6170	2110 x 2110 x 5660	3800kg	£4,000
SC800	2140 x 1125 x 1490	1750 x 850 x 1250	1500kg	£35,000
SC3000	2430 x 2440 x 2990	2180 x 2165 x 2560	4000kg	£35,000
SC6000	2940 x 2560 x 6320	2240 x 2200 x 5660	9000kg	£35,000



- Transportable high security container
- From the outside it looks like an ordinary container
- Ideal for the transportation of cash, weapons, explosives or sensitive confidential data
- Ideal for battery energy storage systems (BESS)
- Option to fit out the inside with internal walling, power, lighting and air conditioning
- Optional weapon racking and ammunition storage
- Optional anti ricochet
- Optional ballistic walling
- Optional GPS tracking can be added
- Optional side personnel door
- Double door access to maximise the opening space
- Ideal for events and exhibitions
- Ready made solution for fast deployment in an existing building
- SC10 and SC20 - tested and certified to SS3492 by SSF/SBSC
- SC800, SC3000 and SC6000 - tested and certified to EN1143-1 Grade 3 by SSF/SBSC

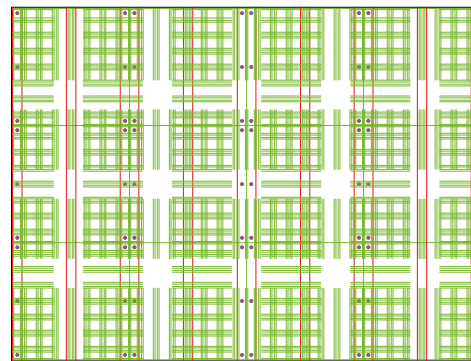
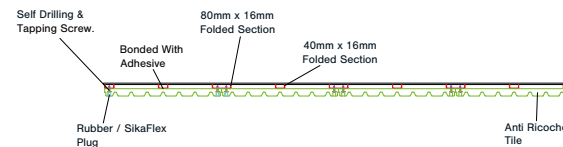

Anti ricochet matting



A Lifesaving Haven for People in Times of Crisis

Underground Bunkers

Underground Bunkers can provide the perfect safe room solution for protecting your loved ones and possessions.

We can create bunkers for installation that will protect you and your family from outside dangers. Customisable secure rooms with various access options for your needs that can be kitted out to your design.

Using a high security steel walling system and security doors we can create your survival bunker room for peace of mind that your family are protected.



Blast proof options

Air filtration system

Highly efficient design

Maximum blast protection

High-quality steel and reinforced concrete

Additional emergency doorz





Elegance and security

ARMOURED SECURITY DOORS

Elegance and security designed for the protection of your family and valuables.

TO BE DEFINED AS "PERFECT" A DOOR NOWADAYS MUST BE SAFE. MUST BE ABLE TO UPDATE THE MOST ADVANCED TECHNOLOGICAL LOCKING SYSTEMS.

IT MUST BE FUNCTIONAL, I.E. CAPABLE OF IMPROVING ITS SECURITY, INSULATING AND ACOUSTIC PERFORMANCE.

FINALLY, IT MUST BE ELEGANT AND CUSTOMISABLE TO RESPOND TO ANY TECHNICAL-AESTHETIC CHOICE.

All our armoured doors have been tested and certified in the laboratory to ensure maximum protection and security from break-in attempts. The ability to resist is measured through the stress with static and dynamic loads, and the simulation of burglary attempts implemented with different types of both manual and electric tools.

In some situations, in addition to protection from burglary attempts, fire protection is required. To meet these needs, we offer two models with fire resistance certification of 30 minutes (Fire 30') or 60 minutes (Fire 60').

Janus Door



METAL+ DOORS
AT THE HEART OF EVERY HEINEN DOOR

KRONOS



Panzer DOORS

JANUS

JANUS SECURITY DOORS



- High security door for homes, offices, banks and prestigious or listed buildings
- Independently attack tested to EN1627 RC3 - RC4
- Custom made to suit your property
- A range of fittings and door furniture available
- High environmental performance - Industry leading energy efficiency
- Superb thermal and sound insulation
- External models offer high levels of air tightness, water resistance and wind resistance
- Choice of key or electronic locking
- Special subframe to aide installation, increase security and can give additional thermal insulation on request
- Security glazing available on request
- Bullet resistance available on request
- Emergency and panic hardware available on request

Locking Options

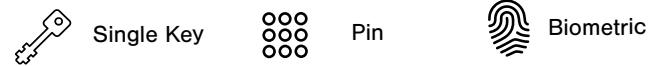

WITH A JANUS DOOR YOU CAN PROTECT WHAT MATTERS MOST TO YOU.

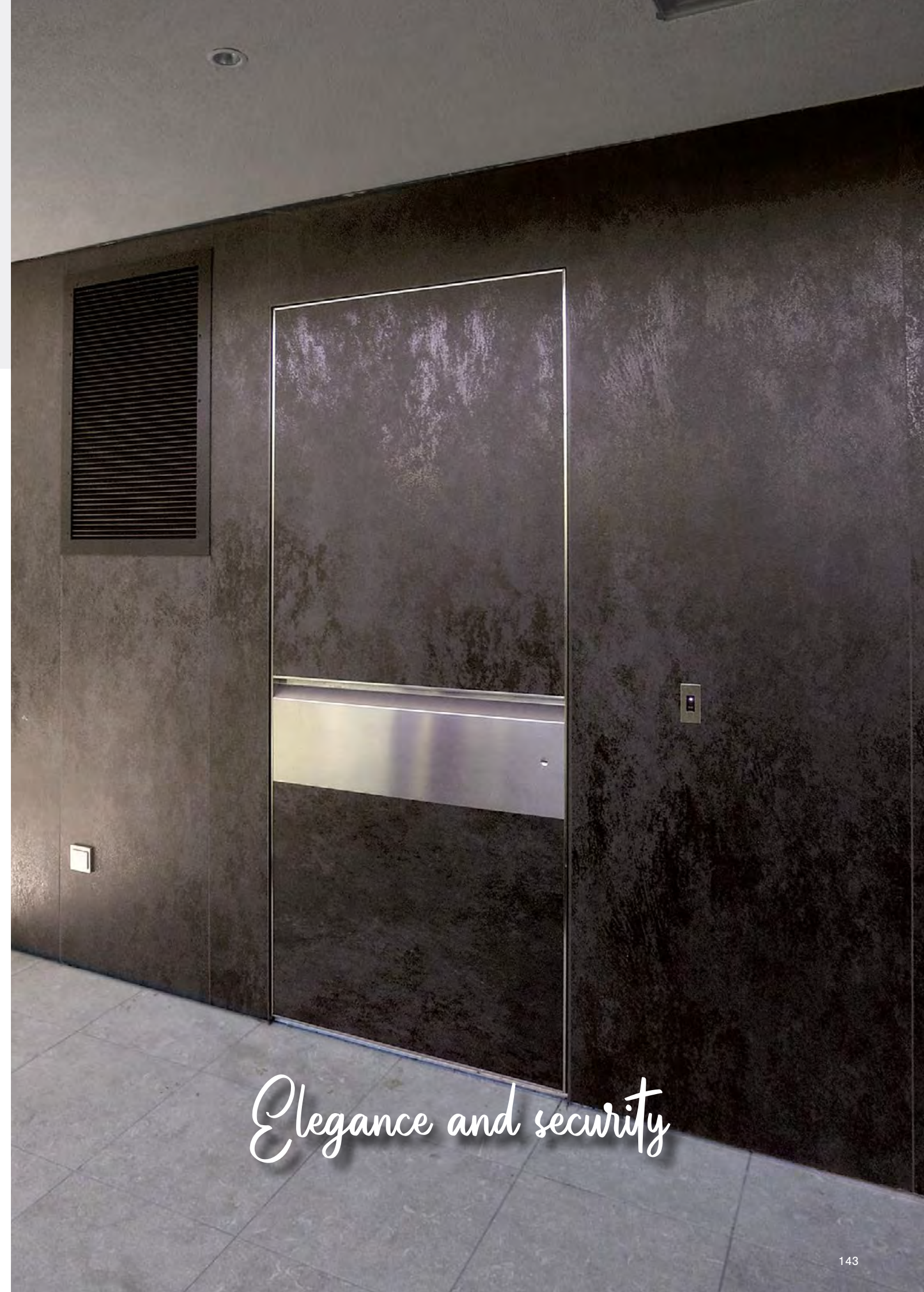
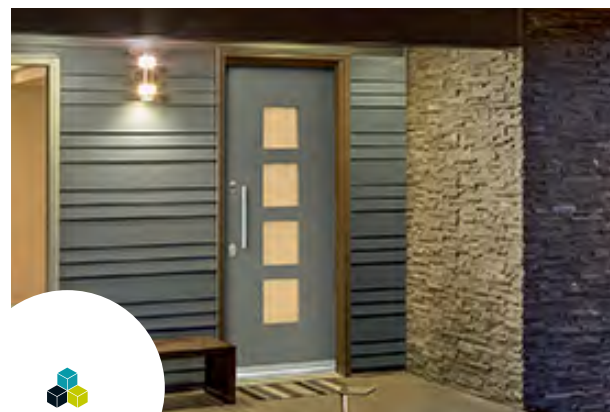

Elegance and security



Outside door view

Door Model	Janus 3	Janus 4	Janus Fire	Janus 3ex	Janus 4ex	Janus Gold	Janus Platinum
Location	Internal	Internal	Internal	External	External	External	External
Security Grade	EN1627 RC3	EN1627 RC4t	EN1627 RC3	EN1627 RC3	EN1627 RC4	EN1627 RC4	EN1627 RC3
Accoustic Insulation	-43dB Rw	-44.8db Rw	-43dB Rw	-44.8dB Rw	-44.8dB Rw	-46dB Rw	-46dB Rw
Thermal Insulation	1.3W/m2K	1.2W/m2K	1.6W/m2K	0.54W/m2K	1.2W/m2K	0.6W/m2K	0.54W/m2K
Air Tightness	N/A	N/A	N/A	Class 4	Class 4	Class 4	Class 4
Water Tightness	N/A	N/A	N/A	Class 6A	Class 3A	Class 9A	Class 9 A
Wind Resistance	N/A	N/A	N/A	Class C4	Class C4	Class 5	Class 5

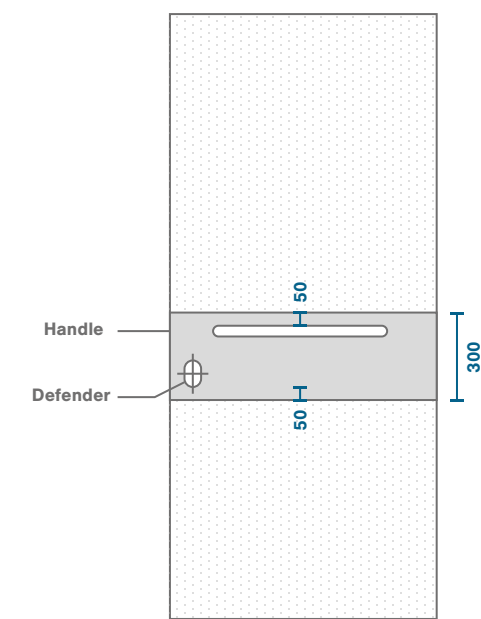
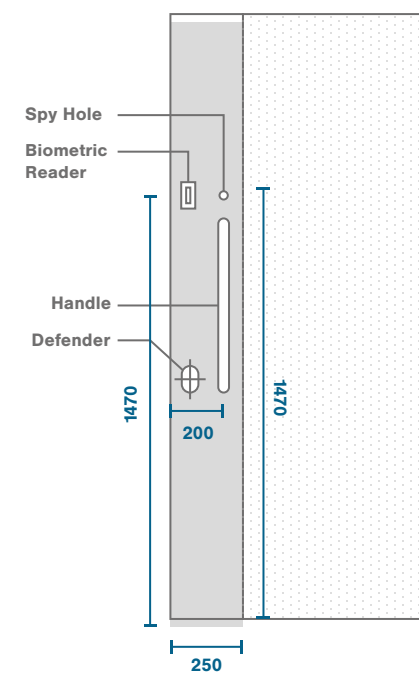
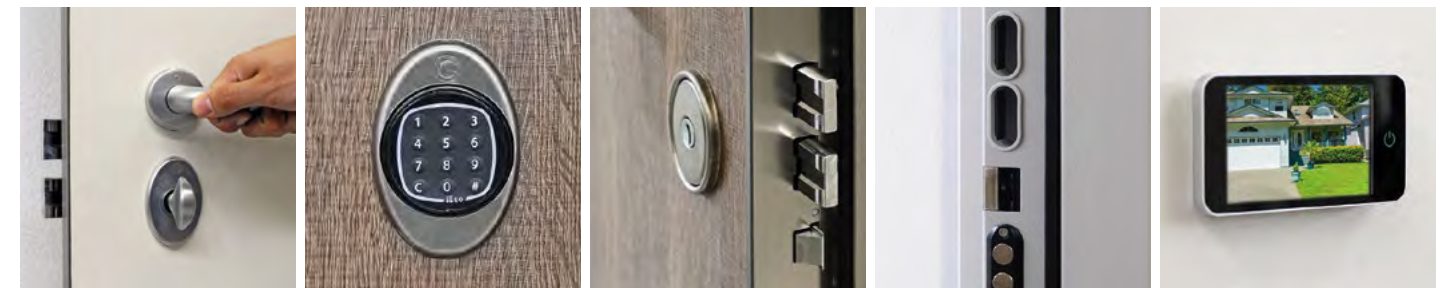



METAL+ DOORS

AT THE HEART OF EVERY HEINEN DOOR

From the simplest to the most demanding requirements



The Heinen heavy duty, high security steel doorsets offer an unrivaled combination of performances. Options include burglary, fire, smoke, bullet & blast resistance, alongside high acoustic & thermal performance as well as options for emergency & panic escape.

The Metal+ steel doors have always remained faithful to their primary objective: to provide protection while guaranteeing stability and robustness that enable heavy-duty use of the door.

Components of the Metal+ door

- Internal tubular steel framework
- Screwed on metal sheets in galvanised or stainless steel
- Adjustable screwed on hinges for precision fitting



The winning combination for a minimal total cost

- Robustness and extreme mechanical resistance
- Very low cost of use : simple to replace components + low maintenance
- Combining high performance features
- 10 or 15 years warranty defined by the installation method

Components of the Metal+ Door

Metal+ Doors have the following basic performance features

- 1 Frame (steel sheet 15/10 or 20/10) covering the thickness of the reveal for an attractive finish (with optional thermal break).
- 2 Double lip seal.
- 3 Insulation around the edges of the door (with intumescent material for fire doors).
- 4 Tubular steel structure (60 x 60 x 2 mm).
- 5 Door skin comprising 15/10 galvanised steel sheet screwed into the tubular structure and individually replaceable.
- 6 Self-lubricating hinges, adjustable and replaceable, screwed into the tubular door structure.
- 7 Hyper-strong synthetic material (for optimum protection of the insulation or intumescent material incorporated into the door leaf).

Combining bespoke performance features

Heinen doors can combine performance features on a bespoke basis. Depending on your needs, one or more performance features are added to the basic, robust METAL+ door.

Fire resistance

EN 1634-1
EI1 30, 60, 120
EI2 30, 60, 120, 180, 240
EW 30, 60, 120, 180, 240
HCM 120/CN240 (N3)

Burglary resistance

EN 1627-1630
RC2, RC3, RC4, RC5
AE20
NF P20-551 & NF P20-311
Niv.5 cat.B / Niv.5 cat.B+

Acoustic performance

EN 717-1: Rw (C; Ctr) dB (A)
36 (-1; -2) to 55 (-2; -7)

Bullet-proof

EN 1522-1523
FB4, FB5, FB6, FB7
AK47

Blast-proof (Only in static calculations)

Electromagnetic shielding (on demand)

Anti-panic EN 179 & EN 1125 (emergency exit devices)

Smoke tightness EN 1634-3 Sa, Sm (200 °C)

Thermal insulation EN 10077-1 & EN 10077-2 Up to 1,5 W/m2K

Airtightness EN 1026 & EN 12207 L1, L2, L3, L4

Watertightness EN 1027 & EN 12208 E0 to E9 + E750

Wind resistance EN 12211 & EN 12210 VC4

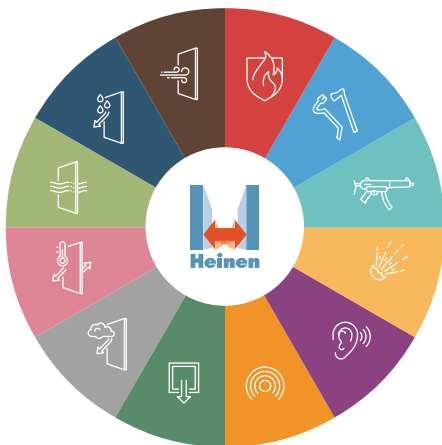
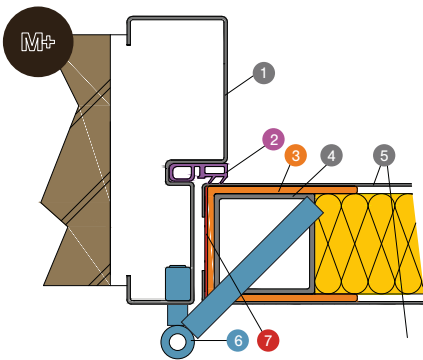

KRONOS SECURITY DOORS

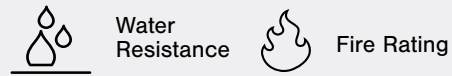

- High security steel doors
- Independently tested and certified to LPS1175 SR2 - SR4
- Optional 240 minutes fire rating*
- Optional flood protection
- Insurance approved by the AiS
- Built to a Police Preferred Specification - Secured by Design
- Suitable for use in any high security environment including; banks, utility sector, retail outlets, jewellers, government, defence buildings and airports
- Custom made to fit your property size and operational requirements
- Inward or outward opening door leaves
- Single or double door sets
- Variety of locking options and optional fittings
- Available in almost any RAL colour**
- 10 year anti-rust warranty



*max 60 minutes with vision panels **some colours are at an additional cost



LPS1175: Issue 7
Cert No: 1000 a



Police Preferred Specification



Variant	Min Height	Max Height	Min Width	Max Width
SR2				
Single inward opening	1000	2930	600	1430
Double inward opening	1000	2930	900	2600
Single outward opening (with removable over panels)	1000	3930	740	1430
Double outward opening (with removable over panels)	1200	3930	900	2600
Single outward opening	1000	2930	600	1430
Double outward opening	1000	2930	900	2600
Single outward opening (with fixed side and over panels)	1000	3930	740	4180
Double outward opening (with fixed side and over panels)	1200	3930	900	5200
SR3				
Single outward opening	1000	2930	600	1430
Double outward opening	1000	2930	900	2600
Single inward opening	1000	2430	600	1430
Double inward opening	1000	2430	900	2600
Single outward opening (with fixed side and over panels)	1200	4125	600	1430
Double outward opening (with removable over panels)	1200	4125	900	2600
SR4				
Single outward opening	1000	2930	600	1430
Double outward opening	1000	2930	900	2600
Single inward opening	1000	2430	600	1430



*Blast protection for personnel
and facilities*



PANZER BLAST PROOF DOORS BT



**Our mission is the protection of persons and facilities.
For this purpose we develop and manufacture blast doors and blast equipment in different versions.
The commitment to design and technical precision was instrumental for our company success.**

Panzer Blast Proof Doors BT built in highly efficient design by means mixture of high-quality steel and reinforced concrete.

The BT1, BT2 and BT3 are swing doors with lateral hinges to allow opening from in-and outside.

The doors are tested in the laboratories under real conditions and Simulated calculation by LS-Dyna and certified that they resists a shockwave from up to 9 bar/130 psi till a explosion pressure (reflected pressure) up to 28 bar/406 psi.

The doors can be equipped with an additional emergency door which is operated from both sides.

APPLICATIONS

- Tunneling protect
- Petrochemical industry
- Power plants
- VIP shelters
- Civilian shelters
- Military shelters
- Industrial shelters

RELATED SECURITY

Products



BESS Battery Energy Storage System



Security Windows



Access Control



Ballistic Window Film



Bar Sets and Grilles



Ballistic Glazing



Certified Security Shutters



Security Window Counters



Key Management Systems



Windows Grilles



Cash Trolleys



Interlock Systems



Ajax Grilles & Cages

- High security retractable grilles and cages
- Suitable for domestic and commercial properties
- Custom made to suit your individual needs
- Available in almost any RAL colour*
- Blast tested using 100kg charge at 20m behind glass backed with anti-shatter film
- Allows line of sight for guarding and CCTV
- Neatly folds away out of sight when not in use
- No hot works required during installation

* some colours at additional costs



Typhon Bar Sets

- High security fixed bar sets
- Independently tested and certified to LPS1175 SR2 - SR4
- Built to a Police Preferred Specification - Secured by Design
- Suitable for internal or external installation
- Custom made to suit your individual needs
- Available in almost any RAL colour*
- Reveal or face fixing options available
- Suitable for mounting to brickwork, concrete or steel
- Minimum 500mm x 500mm
- Allows line of sight for guarding and CCTV

* some colours at additional costs



LPS1175: Issue 7
Cert No: 1000 h



Police Preferred Specification



Talos Walling



- Built to a Police Preferred Specification
 - Secured by Design
- Create a secure room separate from or within an existing property
- Can be used in residential or commercial properties for panic rooms and secure enclosures
- Models with independent testing to LPS1175 SR2 - SR5
- Special lightweight systems allow use in upstairs locations
- Different systems available to suit different risks and budgets
- Optional ballistic protection certified to EN1522/23 FB2 - FB6
- Optional fire protection up to 4 hours
- Can be used for storage of source materials as required by the Environment Agency



Panel Model	Panel Thickness	Weight p/m2	Max Ceiling Span*	Fire Rating Integrity / Insulation
SR2	100	40kg	5500	144min / 30min
SR3	100	45kg	5500	144min / 30min
SR4	100	60kg	5500	240min / 90min
SR5	100	95kg	3500	84min / 84min
FB6	146	135kg	Project specific	240min / 90min

*Without supports

Avertic Armour

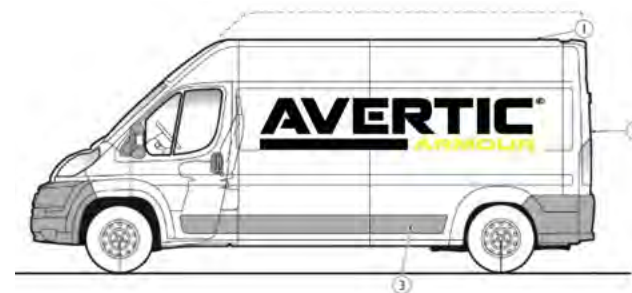

Avertic Armour is a highly advanced, state of the art security panel providing ultra-light and effective protection against a range of power tools. It's unique properties allow it to be used across many security solutions such as cash-in-transit vehicles, panic room construction, military out buildings, secure room dividers, roller shutters and many more.

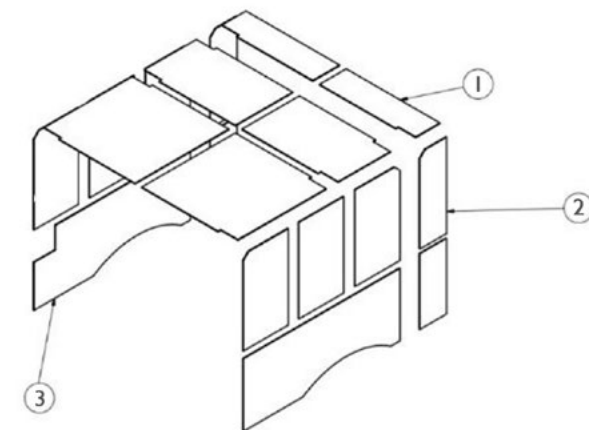

Example of vehicle panel construction

- Designed to withstand attacks from drills, chainsaws, reciprocating saws, concrete cutters and grinders
- Increase the security of armoured vehicles, security walls, security doors, safe rooms, safes, roller shutter and many more security solutions
- Can be used in domestic or commercial properties
- Panels can be cut to any size or shape to meet your requirements
- Space saving solutions as panels are only 5-10mm thick
- Minimal weight increase with panels at just 1 - 1.5kg/pm2
- Easy to apply, and install
- Can be installed as part of manufacture or as a retro fit solution
- 4 different security levels to suit your security needs

Example of secure room wall construction

The Avertic Armour Panel is available in 4 different security levels:

Anti-Drill

Contains 8 layers of protective material and provides 18V drill protection

Power

Contains 6 layers of protective material and 2 layers of the anti-cut material. It can provide protection against a concrete cutter, chainsaw and 800w grinder

Power +

Contains 4 layers of protective material and 4 layers of the anti-cut material. This product protects against a 1100W grinder, reciprocating saw, concrete cutter and chainsaws

Extreme

The most secure level of this product, contains 2 layers of protective material and 6 layers of the anti-cut material. This level protects against a 2300W grinder, reciprocating saw, concrete cutter and chainsaws

Tailored versions are available to suit security requirements

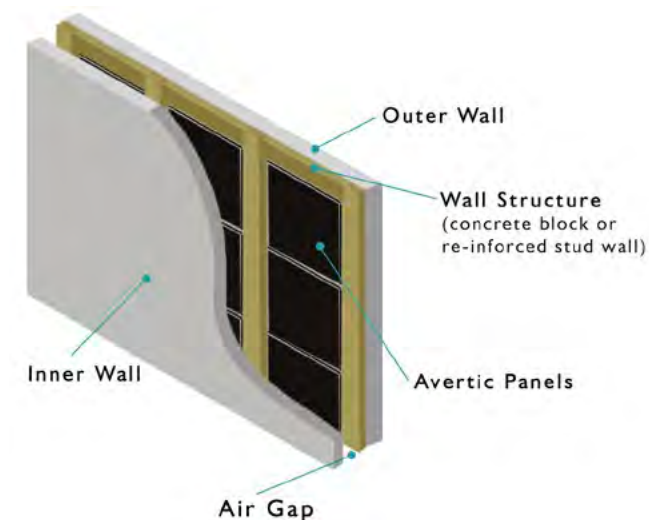



SAFE DEPOSIT

From the world's most advanced safe deposit centres in Hong Kong, to securing cash, bullion and valuables in banks and retailers across Europe and the Middle East; the team at Burton Security have the experience to advise, design and deliver physical security solutions to protect you and your assets.



The High Security team have over 85 years' worth of security industry experience and are qualified in security design and consultancy. Dedicated account and project managers ensure an unrivalled customer experience.

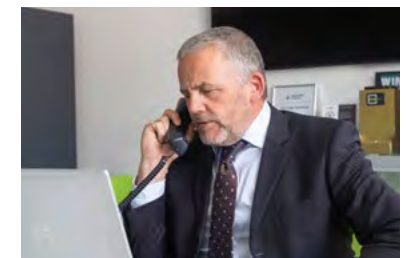

Burton Security core principle is to ensure products are tested to the highest standards. We are proud to have tested products to LPCB standards and feature in RedBookLive.



**Burton Security delivers
The Sure Defence**





SHANGHAI SAFE Deposit Boxes



- A range of low cost safe deposit boxes
- Ideal for use in banks, safe deposit centres or hotels
- Stainless steel facia
- Dual key locking as standard
- 6 different door sizes
- 3 standard depths - 610/510/410
- Optional pull out shelves
- Metal inner box as standard with all sizes*
- Full design and consultancy provided by Burton Safes
- except SSDBB60

Locking Options



Dual
Locking

Box Size	Internal dimensions
SSDBB 60	42 x 120 x 540/440/340
SSDBB 42	65 x 120 x 540/440/340
SSDBB 24	115 x 120 x 540/440/340
SSDBB 21	65 x 250 x 540/440/340
SSDBB 12	115 x 250 x 540/440/340
SSDBB 6	250 x 250 x 540/440/340

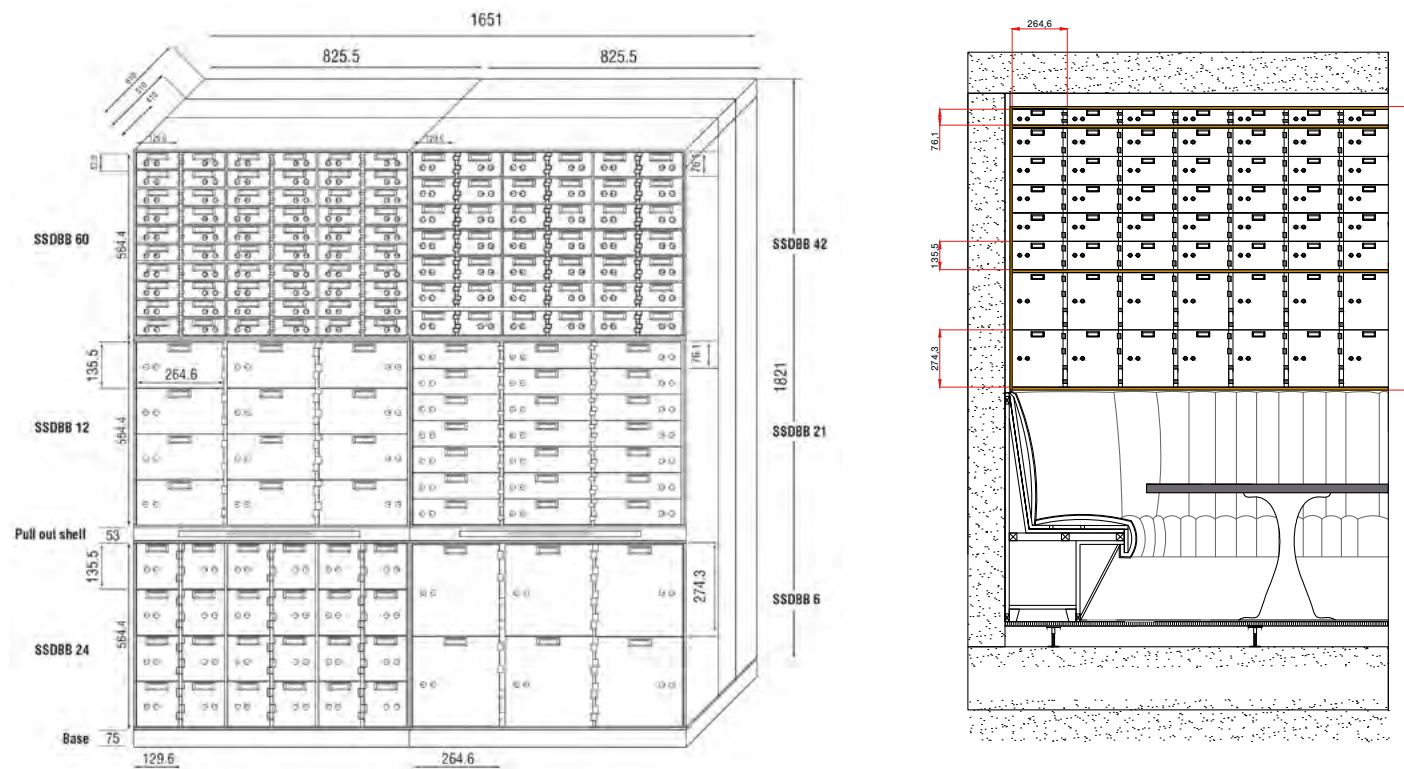

The Shanghai Deposit Boxes are available in different sizes and dimensions to accommodate varying room sizes and storage needs. Our team can work with you to determine the ideal size

Shanghai Safe Deposit Boxes



VIENNA SAFE Deposit Boxes

Locking Options



Single Key



Pin



Biometric

- A range of high quality safe deposit boxes with high security locks and advanced software options
- Ideal for use in banks and safe deposit centres
- 6mm steel door
- Stainless steel facia
- Choice of dual key or key and electronic locking system
- Electronic system offers increased security through permanent monitoring of the door status. Unauthorised entry and tampering will trigger alarms
- Electronic system offers the option of a 'self service system'. Reducing running costs for banks and safe deposit centres
- Vienna Safe Service 6.0 offers the most advanced safe deposit management system on the market
 - control multiple centres, control day gates and interlocks, monitor box status, record client accesses, set up billing functions and run invoicing
- Key locking systems offer a choice of security levels and lock types to suit different budgets
- Plastic inner cassettes as standard with most box sizes
- Also available in different colour options below the stainless steel facia

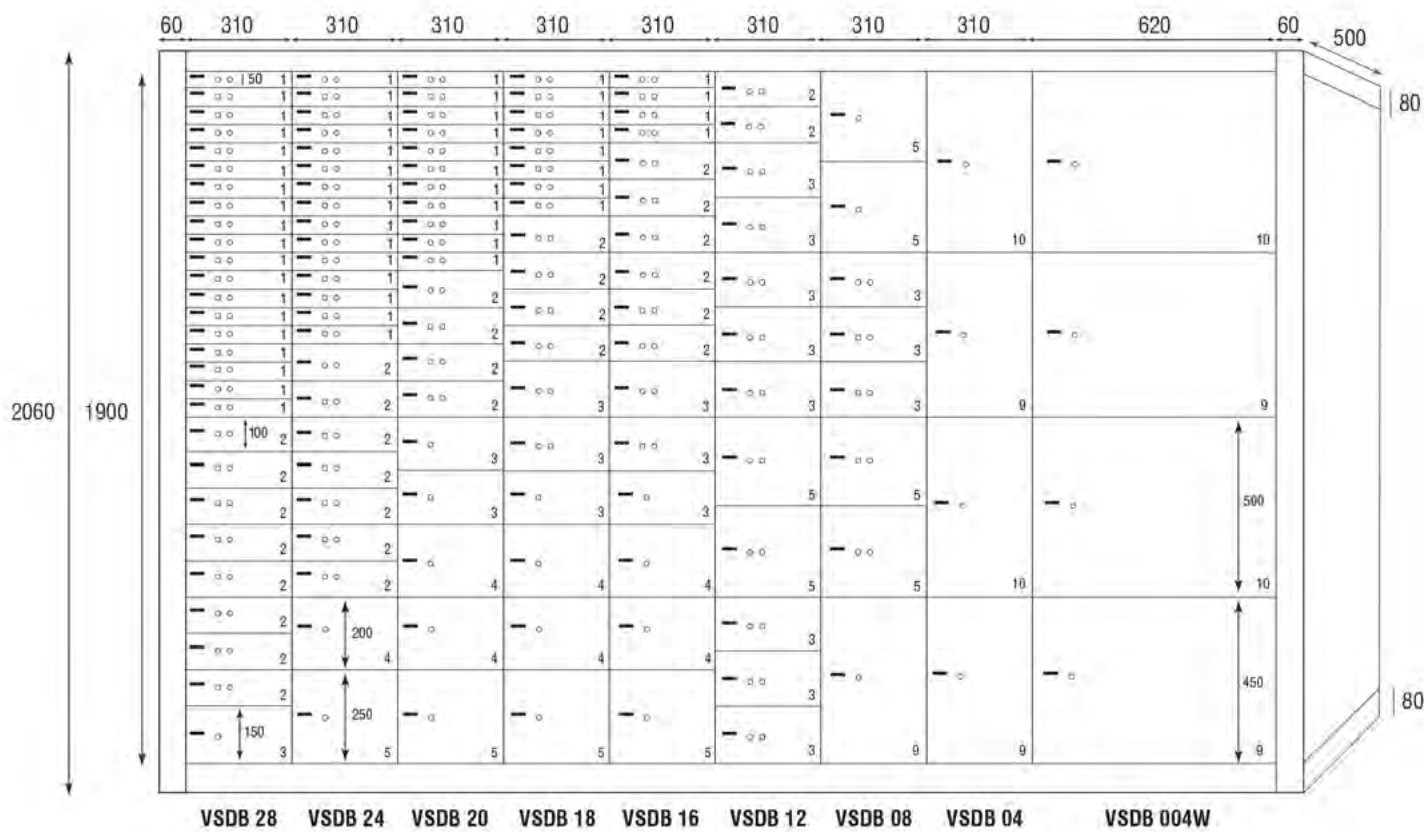

Box Size	Internal dimensions
1	48.5 x 265 x 413
2	98.5 x 265 x 413
3	148.5 x 265 x 413
4	198.5 x 265 x 413
5	248.5 x 265 x 413
9	448.5 x 265 x 413
10	498.5 x 265 x 413
9 W	448.5 x 575 x 413
10 W	498.5 x 575 x 413

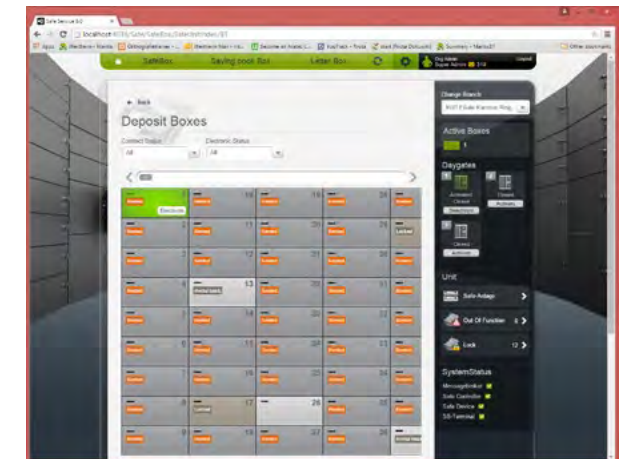

Industry leading self-service software system option available

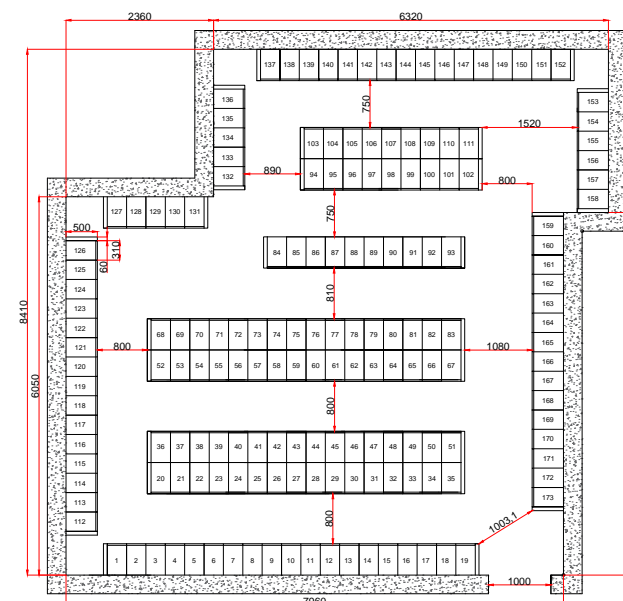

Vaduz Safe Deposit Box System

- 24/7 Self service safe deposit system
- Solid steel lockers
- Lockers come in 4 sizes; 50-230mm (H) x 240mm (W) x 360mm (D)
- Vaults certified to EN1143-1
- Dispense lockers through the wall at ground floor level or via a tower dispense system
- Space saving - two lockers can be stacked one behind the other
- Planning, design, installation and maintenance provided by Burton Safes
- Software for administration and control of safe deposit system
- Spare parts guarantee for 10 years

Locking Options



Pin



Biometric

Box Size	Dimensions
1	50 x 240 x 360
2	110 x 240 x 360
3	170 x 240 x 360
4	230 x 240 x 360

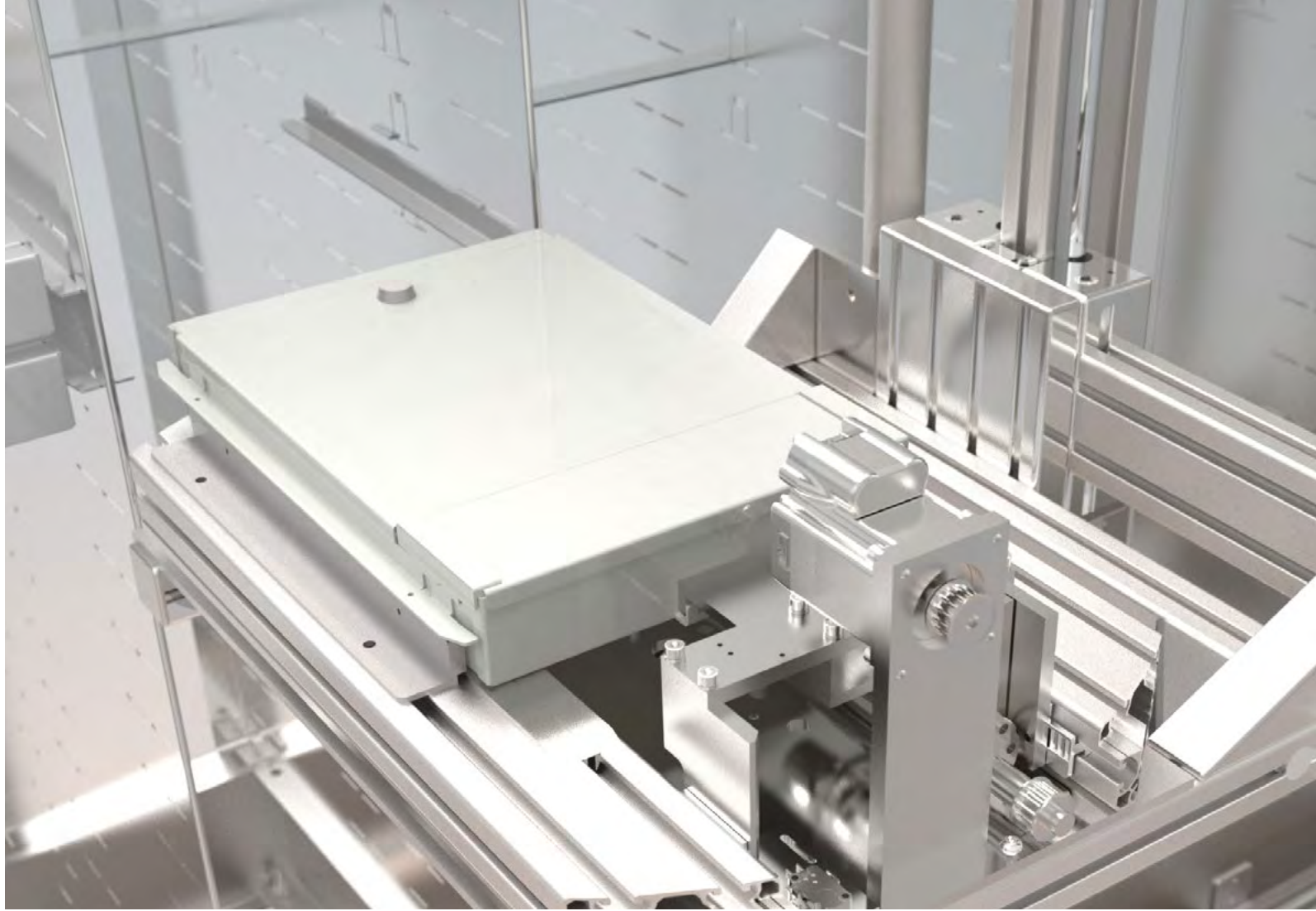
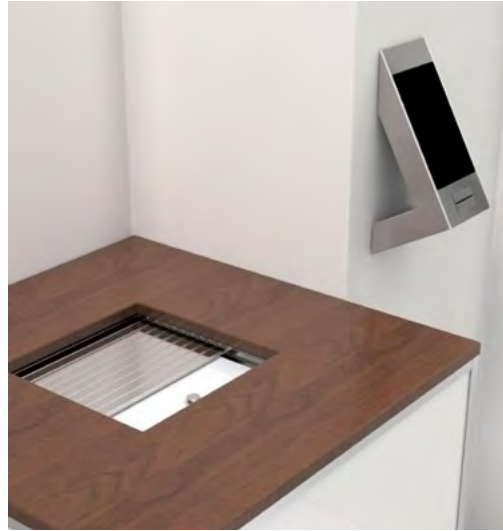
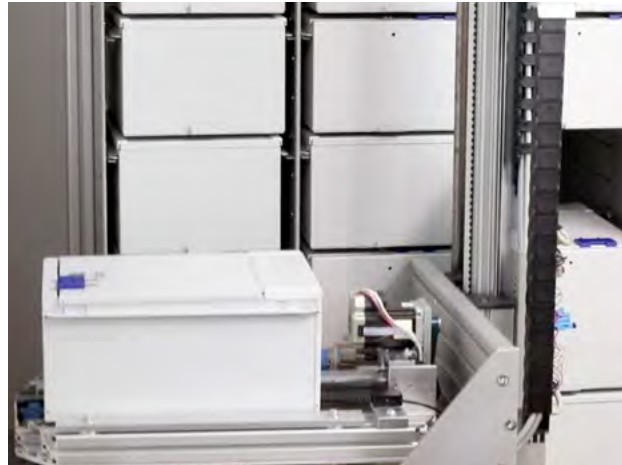

State-of-the-art safe deposit system increasingly used by banks to reduce running costs and offer customers increased access to their deposit boxes. No staff are required for operation of the system and the vault always remains secure. Full design and consultancy is provided by Burton Safes, contact us for more information.

Example of Vaduz vault and safe deposit box construction

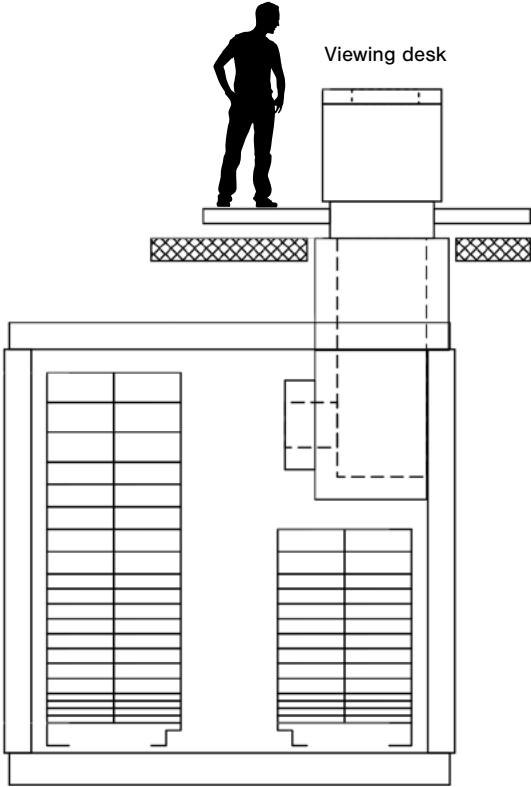
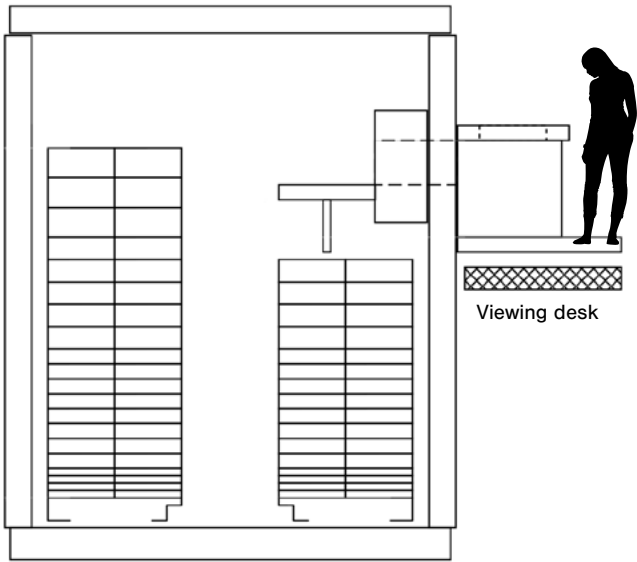



Zurich Safe Deposit System

- Upgrades key locking safe deposit systems to a self service electronic operation
- Reduces staffing costs
- Increase security levels with permanent monitoring of the box status
- Alarms can be generated in the event of unauthorised access
- Simple and quick upgrade with minimal down time
- No need to open boxes to fit the system
- Wireless communication avoids damaging/disrupting the existing room
- Cheaper and less disruptive than changing your boxes to new electronic models

Locking Options



Pin



Biometric





ATM & Banking Security

ATM SAFE HAS OVER 30 YEARS EXPERIENCE WORKING WITHIN THE ATM SECURITY, BANKING, ELECTRONIC SECURITY AND CASH HANDLING SECTORS. WE PROVIDE EXCEPTIONAL QUALITY, CUSTOMISABLE ASSET PROTECTION TO BANKING ORGANISATIONS WHO NEED A RELIABLE PARTNER THAT GOES THE EXTRA MILE.



GAS ATTACK PROTECTION
GP-X



DRILL & CUTTING PROTECTION
Halo Armour
Plus Locks
ACW
ACP
LACP
DACP
E-Frame



RAM RAID & PULL OUT PROTECTION
Halo Armour
Strongarm HD anchor
Strongarm plinth
Sub Terra anchoring



SAFE DOOR PROTECTION
Plus locks
Internal relocking systems
DACP
ACP
LACP
E-Frame



DOOR PULL PROTECTION
ADPS
Anti hook plates
Anti door pull guards



DISPENSER AND ANTI-FISHING PROTECTION
ATM Blocker
DACP
Anti hook plates



ATM ROOM PROTECTION
Embassy ATM rooms and Kronos security doors



ATM REMOVAL PROTECTION
ATM Safe ESP GPS tracking and Alarm monitoring



ATM MONITORING & CONTROL PROTECTION
ATM Pincam,
ATFS power control,
Sentinel safe locks,
Cencon locks



CUSTOMER SPECIFIC DESIGNS
Custom ATM Security Solutions



ATM SERVICES
ATM recoveries
Asset recovery
Safe repairs and upgrades
Installations, removals and moves
Safe lock supply and installations
Servicing

ATM Room Protection Embassy Security Rooms

ATM Rooms

- ATM Rooms & Enclosures
Designed to our Clients Specification
- High Security Doors
- Access Control Options
- Embassy Walling Design
- Fire and Ballistic Protection Available
- Built in ATM Anchoring Options
- Low Voltage Lighting
- Delivered and Installed by our
Expert Engineering Team
- Market Leading 2 Year Warranty



Gas Attack Protection GP-X

Benefits of GP-X

- Fastest Gas Detection Available
- Instant Alarm Activation
- Explosion Protection
- Fire Protection
- Indefinite Gas Attack Protection
- MOD Tested
- Approved by UK Banks
- Approved by ATM Manufacturers
- Proven under Attack
- Award winning ATM Safe System
- Quick Return on Investment



Low Cost
Maximum Protection
Fast Return On Investment

Safe Door Protection Pluslocks

- Re-locker mechanisms built into high security vault doors and safes have been used for centuries, they are intended to keep the door locked during a burglary attempt.
- Upgrade low level ATM Safes to a higher level of protection.
- At the heart of our re-locker system is our Live Pluslock which adds an additional live locking position within the safe that is operated when closing the Cencon lock.
- We have installed 1000's of Pluslocks saving the industry millions of pounds over the years.

Every additional Pluslock installed, adds a higher level of protection



Pull Out & Cutting Protection ACW's, ACP & E-Frame

ACW's

The ACW's have been designed to add an additional 60+ kg of weight each to the ATM. This helps especially in locations the ATMs cannot be bolted down or have poor fixings.

The Cencon ACP

The Cencon ACP has been designed as a fast deploy deterrent (no safe access required) and protection against the cutting and drill attacks below the Cencon lock.

The E-FRAME

The E-FRAME upgrade protects against many of the recent attacks by adding a 60mm steel and composite armoured barrier in key locations of the safe door.



🚧 Ram Raid Protection Strongarm HD

Strongarm Anchor

Solution for all ATM's

Innovative fabricated internal locking system housed within an impact resistant mounting block, installed with low centre of gravity fixings.

Strongarm Plinth

Solution for TTW ATM's

The STRONGARM Anchor Plinth is a heavy duty easy level adjustable plinth designed for ease of installation and adjustment.

Strongarm Subterra

The Subterra Strongarm anchoring system has been tested with our clients in attendance. We employed a professional rescue team to try and lift the ATM out of the ground.



🚪 Door Pull Protection ADPS

Wincor 1500 Solution

The ADPS for the Wincor 1500 ATM is installed behind the safe door as a fixed device with a locking drop in component within the ATM hood.

- Heavy duty steel fabricated internal boss system with built in vertical re-locker
- External drop in locking bolts assembly locked in place using the ATM keys
- Protects the key area where the hook is installed by reducing the forces to the safe door bolt works
- Operated by unlocking the ADPS system top mounting plate by accessing the ATM hood
- The ADPS is unlocked using the same ATM key



🚧 Pull Out & Cutting Protection HALO

The HALO is designed to add complete protection and attack time delay for all internal ATM's

The HALO system is the crown jewels' when it comes to protecting internal lobby ATM's. During the design and production of the system we looked at ATM crime data, met with ATM security managers and also large retailers John Lewis, The Co-operative Group, Tesco, Asda, Morrisons and Aldi to name a few.



🚪 Dispenser & Cash Trapping Protection

DACP, Dispenser & ATM Blocker

DACP – Dispenser Anti cut plate

The DACP is a steel fabrication welded and filled with our own attack resistant chemical composite mix, steel filings and re-bar that is bolted from the inside of the ATM to make a secure tamper proof fixing.

ATM Blocker

We were approached by a US ATM deployer to design a cost effective solution that could be deployed quickly to protect ATM's from cash trapping and transaction reversal fraud attacks.

Dispenser Upgrade

Dual skin dispenser upgrade developed for the NCR 5877 POD ATM to stop easy access and crow bar attacks into the purge and top cassettes. Welded onto the safe door in the workshop. Our engineers upgrade this on a door rotation system to reduce ATM down time.





OTC Smart CIT Lock Sentinel

Sentinel – Custodia

The Custodia is a smart ready high security safe lock and key pad providing one-time code CIT function via QR code. The Sentinel keypad is an elegant and flat design with the option of an inclined keypad variant with battery compartment. All Sentinel locks are VdS and ECB•S approved with the class B lock also having A2P Certified protection against burglary. The perfect upgrade for all ATM estates.

Sentinel – Oculus

The Oculus has all the features of the Sentinel Custodia but takes the lock options to new levels by communicating with our PC software for configuration and administration of the lock system or via the TwinIP extension unit for integrating the lock system into the customer network for full monitoring of the ATM safe lock.

Sentinel – Imperium

The Imperium has all the available features of the Custodia and the Oculus with the additional control via our total lock control PC software to provide full access control and management of entry doors, security doors, access control, key access and the ATM safe locks.

The options are endless –
Please ask us for our expert consultation



Case Study

Burton Security were invited to participate in a tender process for the implementation of a new ATM electronic safe locking solution. After successfully exceeding the tender requirements, we were awarded the opportunity to undertake this rollout across the client's UK network of ATM's.

The project included the supply, installation and project management of circa 1,400 ATM Safe locks across a network of 650+ branches. Working closely with the client we designed a bespoke installation process and timetable suitable for the wide variety of ATM models and operational needs of the business. Throughout the project planning several client specific functionality requests were explored, developed, tested and implemented to ensure client satisfaction beyond the original scope.

After the planning period was completed the physical installations began. Using our network of skilled and qualified safe engineers we successfully installed to each ATM, in both a live branch and factory environment.

Throughout the entire project, regular reviews were undertaken, and actions applied to ensure an efficient and cost-effective rollout. As a result of the detailed pre planning work and an efficient installation process, the project was successfully completed within the client's requested timeframe of 26 weeks, allowing them to reap the benefits of the developed solution as early as possible;



- Freed up branch colleague time, removing involvement in the ATM replenishment process
- Improved security and efficiencies in the management of staff access to the Locks
- Removal of mastercodes management and responsibility - passed to Burton Safes
- Enabling efficient estate wide changes with the use of configuration cards
- Implementation of One Time Code (OTC) functionality without the need for additional infrastructure or IT Involvement including:

- Auto generation of secure OTC for CIT Access
- Real Time lock status monitoring as part of the OTC functionality

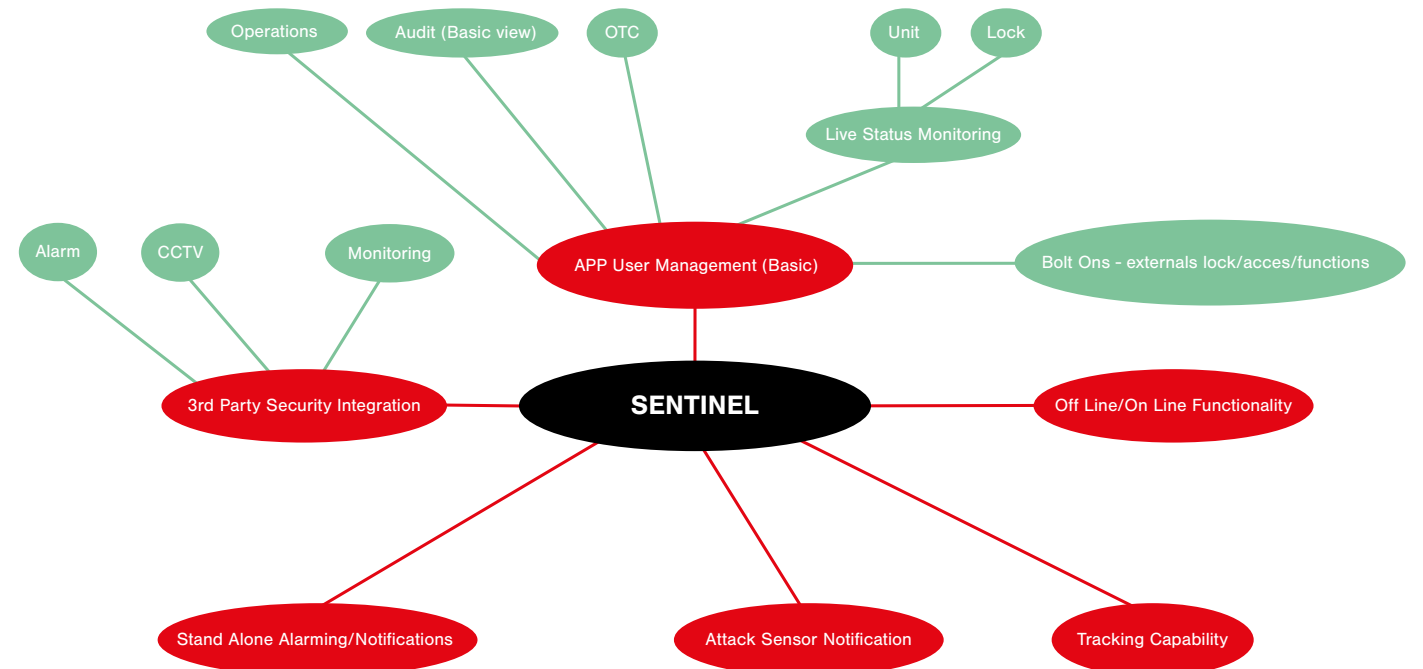



ATM Safe at a glance

£50m +

CASH SAVED

15,000

ATM SECURITY SYSTEM INSTALLED

UK Engineered

DESIGNED AND MANUFACTURED IN THE UK

30 +

YEARS OF EXPERIENCE

Bespoke Products

From a simple drawing on a napkin we can recreate your vision in a unique way using auto-cad to design your concept to using the latest 3D printing and rendering techniques.

All designs are manufactured to the highest quality and tested thoroughly before launch.

We offer complete project management and engineer training for all our national and international partners, this can be done in house or at our head office in the UK.

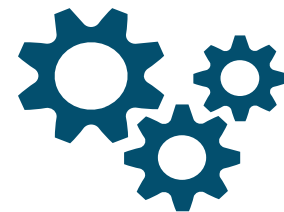

- ATM Pincam
- ATFS power control
- ESP GPS tracking and alarm system
- Custom ATM Security Solutions



DELIVERY AND INSTALLATION SERVICES

ATM RECOVERIES

We offer a 7 day emergency recovery service for our clients in the UK when an ATM has suffered an attack. Our specialist engineers can open safe doors, remove the ATM to our secure storage and make site safe to the public.

ASSET RECOVERY

As part of our recovery team we often meet CIT teams, the Police and open safes so the assets can be recovered urgently and removed from further risk of theft.

SAFE REPAIRS AND UPGRADES

We can repair most ATM's after a physical attack in our workshops. Damaged safe doors and safe bodies can be welded and repaired by our fabrication team, while also being upgraded with ATM SAFE security products, Smaller damage can be repaired and protected on site after criminal activity.

INSTALLATIONS, REMOVALS AND MOVES

ATM SAFE have been providing Installation, Moves & Changes (IMAC services) to ATM companies and the financial sector for many years. Our dedicated project managers ensure we offer the highest level of customer attention and service.



SAFE LOCK SUPPLY AND INSTALLATIONS

As an approved distributor of Kaba, LA Gard and INSYS safe locks we can deliver an exceptional design, supply and installation service using our own qualified field safe engineering team.

SERVICING

Our dedicated ATM service desk ensures all works are professionally carried out by using our own security engineers for all service works, lock fits and security product installations.

enquiries@burtonsecurity.com



ATMSAFE.CO.UK
+44 (0) 1484 663388



Reactive Safe Engineer and Locksmith Service

Burton Security believe in offering exceptional service

Every customer has individual service needs; the internal service team design and deliver bespoke service packages to suit your individual requirements for both safe and locksmith engineering, all of which is supported by a dedicated Account Manager.

The service team is available 24/7 - 365 days a year. Skilled and experienced engineers are located across the UK and ROI, delivering market leading response and first time fix rates - providing you with reduced downtime and cost reductions.

Our business is built on delivering it!

DELIVERY AND INSTALLATION SERVICES

Weekday Deliveries

- Next Day*
- Next Day by Noon*
- Next Day by 10:30am (less than 70kg)*
- Evening 6pm-9pm

Delivery and Position (Weekdays)

- Next Day*
- AM/PM Slot
- 2 Hour Window

Weekday Installations

- Express (2-3 days)
- Pre-9am
- AM/PM Slot
- Evening

Weekend Installations

- Saturday
- Sunday

Our standard delivery is a 2-3 day service and we have a range of delivery and installation options to upgrade your order and suit your needs.

Weekend Deliveries

- Saturday
- Saturday by Noon (less than 30kg)
- Saturday by 10:30am (less than 30kg)
- Sunday (less than 30kg)
- Sunday by Noon (less than 30kg)

Highlands & Islands Deliveries

Republic of Ireland Deliveries

*order by 2pm the preceding day

Installation Special Services

- Highlands and Islands
- Unmarked Vehicle Service
- 1st Floor/Basement via Stairs*
- 2nd Floor/Basement via Stairs*
- Hiab, Crane or Specialist Vehicle*

*Site Survey Dependent



Burton Security service agreements cover all types of safe and lock, some of the features include;

- Supply and installation of physical security products
- Emergency reactive response
- Emergency safe and door opening
- Lock upgrades and re-programming
- Preventative maintenance
- Safe removal and disposal
- Cover for all brands of locks and safe
- Dedicated Account Manager
- A single point of contact for all issues
- Free access to our in house technical help desk
- Average response times of under 3 hours
- Average time on site of less than 1 hour
- Average first time fix rate of 97%
- European cover also available

BESPOKE SECURITY SOLUTIONS



Contact our commercial team
+44 (0) 1484 663388
enquiries@burtonsecurity.com



Although Burton Security offers an extensive range of tested and certified safes, vaults and physical security products, our R&D and engineering

side of the business have the capability to provide made to measure bespoke security solutions to meet the most demanding of projects.

STANDARDS

The Sure Defence

All strongrooms certified to EN1143 must have a certified lock that reflects the grade of the solution

- Strongrooms certified to EN1143-1 Grade XI and XII must have 3 locks certified to Class C or 2 locks certified to Class D
- Strongrooms certified to EN1143-1 Grade XIII must have 2 locks certified to Class D

The standards below can be found in our Sure Defence ranges:

LPS1175 - This is an independent standard published by BRE. It can be applied to products used to form all layers of physical security, including the perimeter (e.g. fences and gates), building fabric (e.g. doors, windows, shutters and walling), enclosures and cabinets. Issue 8 defines eight levels of threat (A to H) and six levels of delay (1, 3, 5, 10, 15 and 20 minutes).

EN1627 - This is a European burglary attack test standard for security doors. There are 6 security levels from RC1 - RC6

EN1063 - This is a bullet resistance test for glass. There are 7 levels from BR1 - BR7

EN1522 - This is a bullet resistance test for doors and systems. There are 7 levels from FB1 - FB7. All parts of the door are tested, including door furniture, frames and joints



LPCB EXPLAINED

LPCB certification is recognised by insurers, consultants, architects and risk managers across the globe.



Products that are tested to LPCB standards can reduce liability for our customers because of the demonstrated due diligence that having a product certified provides.

Products are rigorously assessed in order to achieve certification. Testing and evaluation makes up an early part of the process, followed by auditing the factory production to ensure high standards are maintained.

Once the product is successfully certified, it is then listed on [RedBookLive](#). It is here that our products are seen by specifiers to verify the status of our tested products.

Once a product has been certified, continuous audits are carried out to ensure that certification is maintained.

Product	Standard	Rating	Certification
PANIC ROOMS AND WALLING			
Embassy Panic Rooms	-	-	-
Talos	LPS1175 Issue 6	SR2, SR3 and SR4	LPCB
Avertic	-	-	-
SECURITY DOORS			
Janus	EN1627	RC3 and RC4	Istituto Giordano
Metal +	EN1627	RC2 to RC5 - FB4 to FB7	-
Kronos	LPS1175 Issue 7	SR2, SR3 and SR4	LPCB
GRILLS AND BAR SETS			
Ajax	-	-	-
Typhon	LPS1175 Issue 7	SR2 and SR3	LPCB
VAULTS AND STRONG ROOMS			
Transporta - SC10 & SC20	SS 3492	SS 3492	SSF/SBSC
Transporta - SC800, SC3000 & SC6000	EN1143-1	Grade 3	SSF/SBSC
Orthrus	LPS1175 Issue 8	F10 (SR6) G5	LPCB
Cerberus	EN1143-1	Grade 1 to Grade 13	ECB•S

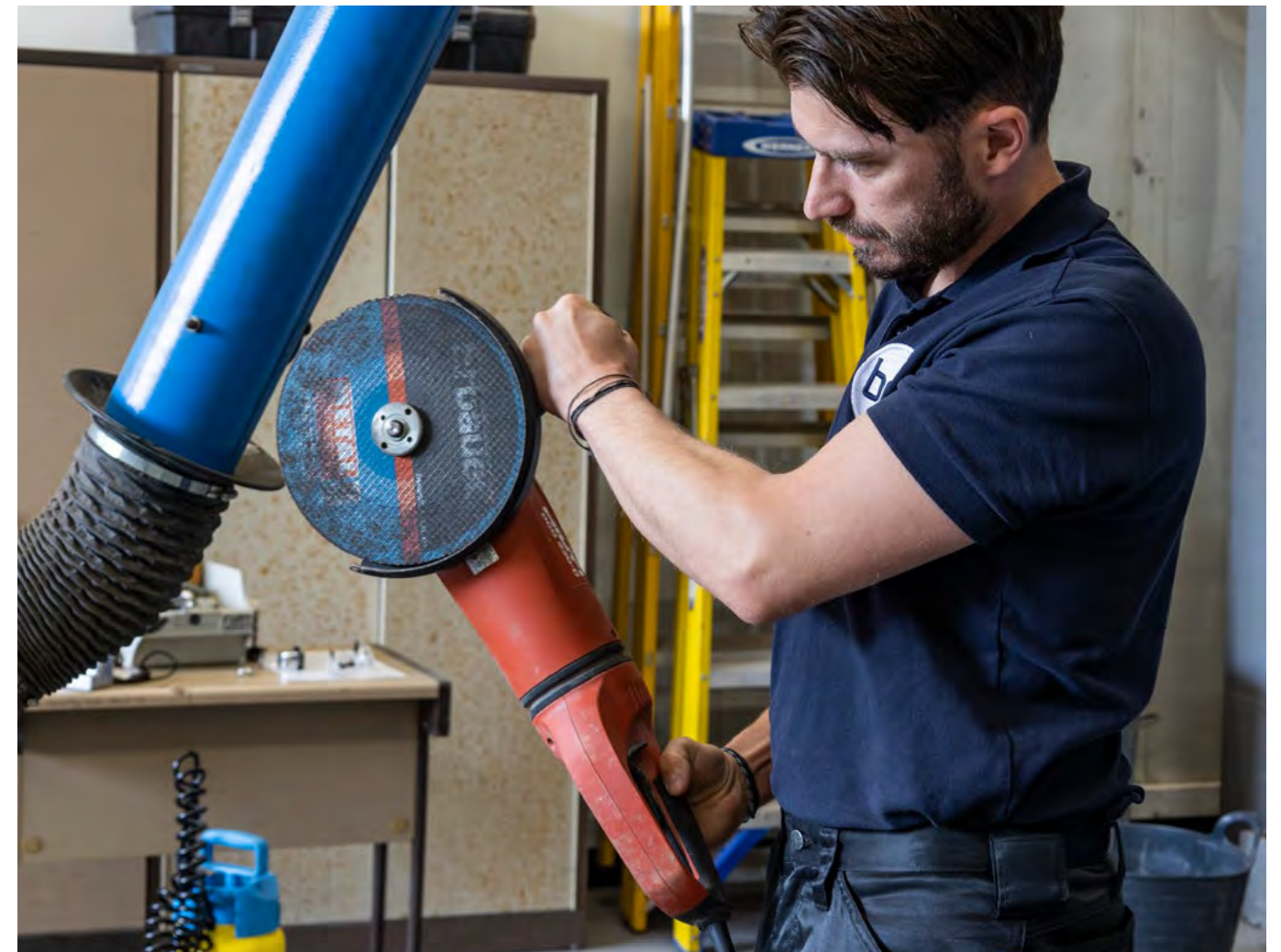

**IF IT MATTERS TO YOU,
SECURE IT WITH US...**

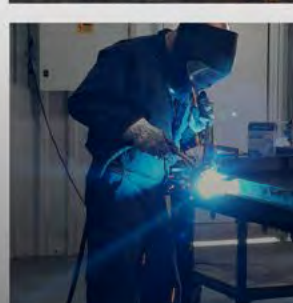
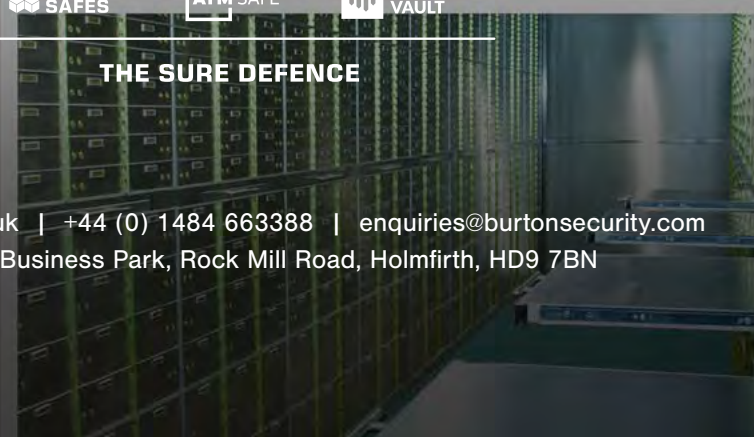
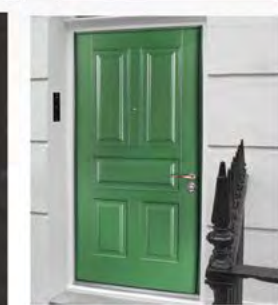
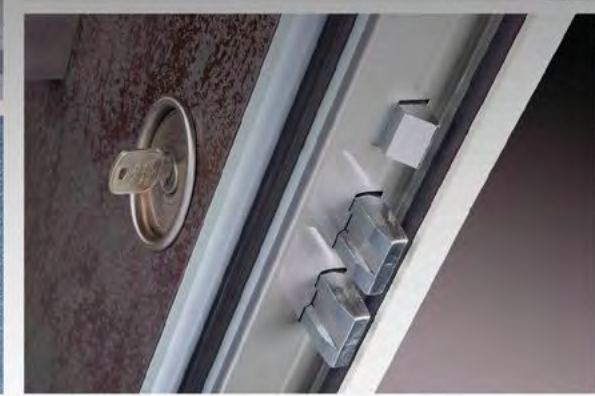
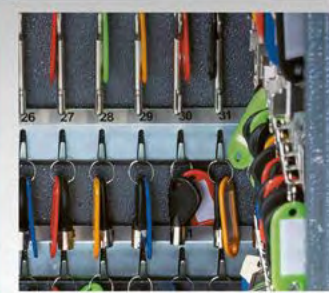
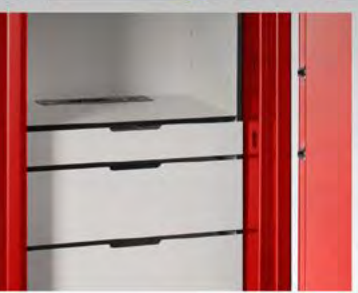
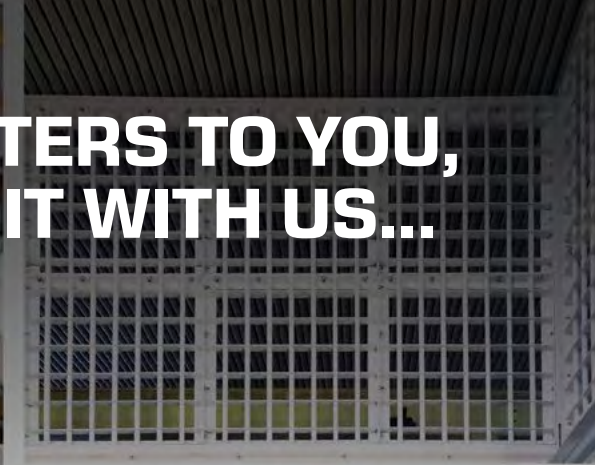

**BURTON
SECURITY**

**BURTON
SAFES**

ATM SAFE

**SAFES &
VAULT**

THE SURE DEFENCE

www.burtonsafes.co.uk | +44 (0) 1484 663388 | enquiries@burtonsecurity.com
Brockholes Business Park, Rock Mill Road, Holmfirth, HD9 7BN